



PCXDMT1901



Catalogue/Technical Manual



# DM-AHU

Double Skin Modular  
Air Handling Unit  
(ROUND EDGE)

Air Flow: From 1,100 To 90,000 m<sup>3</sup>/h



# CONTENTS

<b>1.0 INTRODUCTION</b> .....	1
<b>2.0 NONMENCLATURE</b> .....	1
<b>3.0 AHU DESIGN FEATURES</b> .....	2-11
3.1 DAIKIN DM STANDARD FEATURES.....	2
3.2 CASING / CABINET CONSTRUCTION .....	2
3.3 THERMA BREAK PROFILE .....	3
3.4 COIL SECTION.....	5
3.5 DRAIN PAN .....	5
3.6 FACE AND BY PASS DAMPER.....	6
3.7 FAN .....	6
3.8 MOTOR .....	7
3.9 FAN / MOTOR ASSEMBLIES.....	7
3.10 VIBRATION ISOLATOR.....	8
3.11 THERMISTOR.....	8
3.12 VFD/ FREQUENCY INVERTER.....	8
3.13 ENERGY RECOVERY.....	8
3.13.1 HEAT RECOVERY WHEEL.....	8
3.13.2 HEAT PIPE.....	9
3.13.3 PLATED HEAT EXCHANGER.....	9
3.14 HUMIDIFIER.....	10
3.15 ELECTRIC HEATER.....	10
3.16 FILTER SECTION.....	10
3.17 QUICK AIR FILTER SELECTION GUIDE.....	11
3.18 MIXING BOX.....	11
3.19 SOUND ATTENUATOR.....	12
3.20 ULTRA VIOLET GERMICIDAL IRRADIATION (UVGI) .....	12
<b>4.0 STANDARD UNITS QUICK SELECTION TABLE</b> .....	13-14
<b>5.0 OUTLINE AND DIMENSION</b> .....	15-21
5.1a HORIZONTAL TYPICAL CONFIGURATION TYPE 1 & 2.....	15
5.1b HORIZONTAL TYPICAL CONFIGURATION TYPE 3 & 4.....	16
5.1c HORIZONTAL TYPICAL CONFIGURATION TYPE 5 & 6.....	17
5.1d HORIZONTAL TYPICAL CONFIGURATION TYPE 7 & 8.....	18
5.1e HORIZONTAL TYPICAL CONFIGURATION TYPE 9 .....	19
5.2a VERTICAL TYPICAL CONFIGURATION TYPE 1 & 2.....	20
5.2b VERTICAL TYPICAL CONFIGURATION TYPE 3 & 4.....	21

<b>6.0 APPLICATION CONSIDERATIONS</b> .....	22-24
6.1    INSTALLATION FLEXIBILITY.....	22
6.2    MOUNTING AND ACCESS.....	22
6.3    DUCTWORK.....	22
6.4    PIPING AND DRAIN PAN TRAPS .....	23
6.5    AIR SUPPLY SYSTEMS AND FAN LAWS.....	23-24
<b>7.0 FAN SPECIFICATION</b> .....	25-26
7.1    FAN DISCHARGE ARRANGEMENT.....	27
<b>8.0 FAN MOTOR SPECIFICATION</b> .....	28
<b>9.0 BELT AND PULLEY SPECIFICATION</b> .....	29
9.1    PULLEY ALIGNMENT.....	29
<b>10.0 COIL SPECIFICATION</b> .....	30-36
10.1    COIL SIZE AND FACE AREA.....	31
10.2    HEADER SIZE.....	32
10.3a    HEADER DIMENSION- SINGLE COIL.....	33
10.3b    HEADER DIMENSION- 2 LAYER COIL.....	34
10.3c    HEADER DIMENSION- 3 LAYER COIL.....	36
<b>11.0 HEAT RECOVERY WHEEL SPECIFICATION</b> .....	37
<b>12.0 FILTER SPECIFICATION</b> .....	38-39
12.1    STANDARD FILTER SPECIFICATION.....	38
12.2    HEPA FILTER SPECIFICATION.....	39

# 1.0 INTRODUCTION

The Double Skin Modular Air Handling Unit is designed based on modular paneling concept to fulfill the indoor air quality requirement. The air flow of DM AHU is within range of 330 to 25,000 lps (1100 to 90000 CMH) and up to a total static pressure of 2000 pa (8" W.G).

The AHU is constructed of high strength extruded Aluminum to form rigid frame. Besides, it is with thermal barrier feature which using three leg-fiber plastic corner pieces, 25 or 50 mm Polyurethane (PU) insulation panel and all frames are insulated with 3.0 mm PE foam to minimize energy heat loss and prevent condensation occurring. The external clip method to hold the double skin PU insulation panel is easily accessible for maintenance while being air tight. The new thermal- break profile with high strength nylon strip can perform better than the original profile in terms of providing better insulation and energy saving.

Selection software program available for DM AHU, to optimize the best arrangement and performance for either chilled water system or DX system. Standard components can be selected and be placed according to customer requirement. Once the unit is defined, optional item and accessories are identified. The program gives immediate feedback if there is no suitable choice for the units. The user friendly selection program provides fan curves data, coil performance data, dimension, and shipment weight.

Daikin is produce high quality, flexibility air handling unit which can provide excellent thermal efficiency and to be airtight. Besides, air handling unit produced is with flexibility features to meet the indoor air quality, operating efficiency, sound level and installation requirement for today's extensive commercial and customize markets. A comfortable environment can enhance human's life quality.

# 2.0 NONMENCLATURE

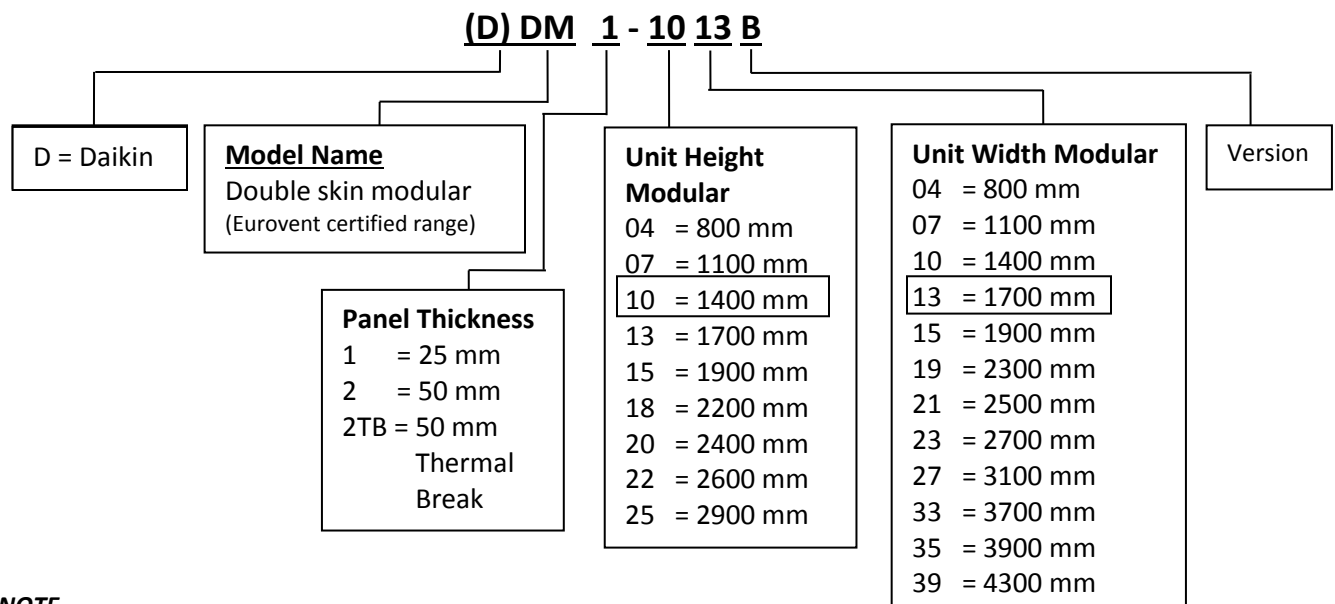

**NOTE**

\* Special customized design for non-standard AHU upon customer request is available.

\* Width and height in above table are based on the 25mm (DM1) panel thickness, additional 50mm (Height & Width) for AHU with 50mm (DM2/DM2TB) panel thickness.

## ■ 3.0 AHU DESIGN FEATURES

### 3.1 DAIKIN DM STANDARD FEATURES

- Variable dimensioning features for flexible cabinet sizing (increment 100mm in height and width)
- External Galvanized and internal painted cabinet
- PUR insulation panel material
- Multiple section depth
- Variable coil casing and drain pan material
- Mixing boxes
- Low leakage damper
- Double sloped drain pan
- Different filter grade
- Variable fan selection include forward-curved, backward curved and airfoil, AC/EC plug fan
- Variable frequency drive / Frequency inverter (VFD) and thermistor
- Electric heater
- Ultra Violet (UVGI)
- Energy Recovery Section ( Heat Recovery Wheel / Heat Pipe / Plated Heat Exchanger)
- Accessible and maintenance
- Flexibility section for shipment

### 3.2 CASING / CABINET CONSTRUCTION

Daikin DM Air Handling Unit is designed in accordance BS EN 1886 and certified under EUROVENT Certification program. It is constructed of high strength extruded round edge aluminum pentapost and flat surface internal intermediate post with double modular skin insulation material. The frame channel design allows three identical pieces to be bolted together to form a composite corner piece. Both of this features form the rigid frame of the AHU. The unit wall is made up by Double Skin Polyurethane foam (PUR) insulation panel with 0.5 mm high strength pre-painted steel as external skin and 0.5 mm galvanized steel (GI) as internal skin. Besides, there are optional thicknesses: 0.8 / 1.0 / 1.2 / 1.5mm of skin material. The PU foam insulation thickness can be 25mm or 50mm with density 40 kg/m<sup>3</sup>.

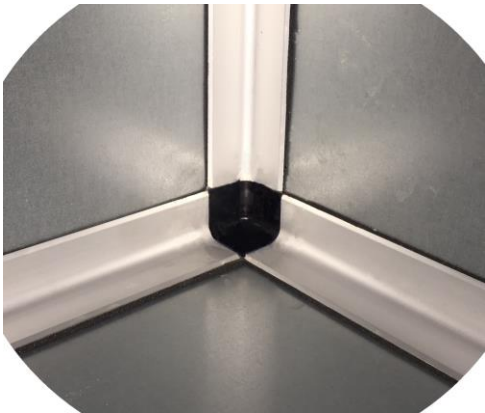

**Figure 1: Round edge aluminum pentapost with 3-legged injection Nylon corner piece.**

This cabinet construction reduces significantly the sound level from the fan of an AHU. The cabinet construction is maintenance friendly through easy access to all components. The panels may be removed from all units sections without compromising the unit rigidity which is ensured by the aluminum frame. The AHU Unit is designed to low energy consumption and no condensation due to high thermal insulation and airtight casings accordance to EN 1886.

Access door or service panel can be supplied with a swing type or removable panel type. Gasket around the full perimeter of the access doors frame shall be used to prevent air leakage. Module to module assembly shall be accomplished with an overlapping splice joint that is sealed



Figure 2: Cabinet Appearance

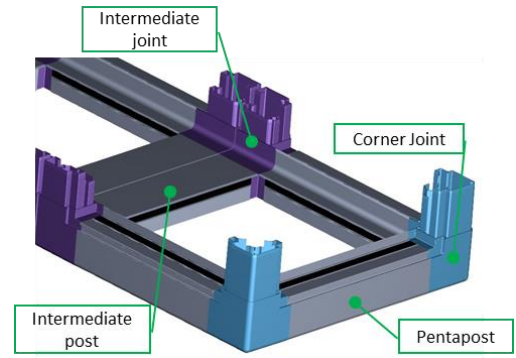

with gasket on both mating modules to minimize on-site labor along with meeting indoor air quality standards. Bolt and nut joining bracket provide easier on-site combine of multiple module. The unit is mounted on galvanized steel base frame for easy handling and positioning.

### 3.3 THERMAL BREAK PROFILE

This is a new and high quality thermal break round edge aluminum profile (DM2TB) which can enhance performance of an AHU. It is constructed of two parts of extruded aluminum joint together with thermal barrier nylon strip. The nylon is sandwiching the inner and outer layers of extruded aluminum. This design could render the formation of an effective isolated thermal layer between the inner and outer side of the profiles so that the release of thermal energy via AHU could be ultimately minimized.

The thermal bridging factor of the assembled DM Air Handling Unit is designed to meet BS EN 1886, Class TB2. The thermal break profile only available for cabinet with 50mm thickness. A good AHU can be determined by: no air leakage and minimum heat loss through the AHU. The benefit of thermal break property showed as below increase the life of AHU and also save their operation cost for using long term. In addition, it is an ideal design for high end performance.

#### Benefit of Thermal Break Profile

- i) Increased Energy Efficiency –System energy efficiency is improved by lowering the heat loss.
- ii) Unit condensation minimized –Exterior condensation is potentially damaging or creating hazardous conditions.
- iii) Probability of moisture migration into panel interior, which can degrade the insulation, is eliminated in this thermal break profile.
- iv) Cut-off in an attempt to achieve energy conservation.
- v) Improve sound insulation.

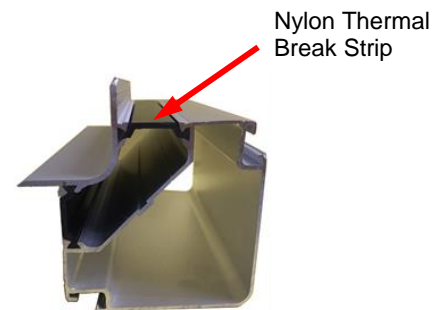

Daikin is well known with its superior quality. DM AHU have also been recognized globally, including under the Certification of **EUROVENT** and are leading-edge. Performance of DM AHU and its mechanical strength, air leakage rate, cold bridge coefficient of the cabinet are tested.

- Eurovent certification is renowned across the world for its high standards and strict requirements on its air conditioner performance. As a result, all Eurovent-Certified products enjoy high credibility.
- Eurovent standards for AHU products include EN1886 and EN13053.
- EN1886 focuses on mechanical features of AHUs, including cabinet strength level, cabinet leakage level, filter by-pass leakage, cabinet heat transfer coefficient, and cold bridge co-efficient.
- EN13053 focuses on performance of the entire AHU, including actual air flow, air pressure, cooling capacity, heat capacity, motor power and noises.



**DM cabinet reaches EN1886 standard**

High Grade  Low Grade

		DM2TB	DM2	DM1	Class Classification of EN1886 standard				
Casing Strength	Strength class	D1(M)	D1(M)	D1(M)	D1	D2	D3		
	Maximum relative deformation of the cabinet under bearable pressure mm/m	4	10	>10					
Casing Air Leakage	Air leakage class	L1	L1	L2	L1	L2	L3		
	Maximum air leakage rate of the cabinet under test pressure of -400 Pa (l/s/m <sup>2</sup> )	0.15	0.44	1.32					
Filter By-passed Leakage	Maximum air leakage rate of the cabinet under test pressure of +700 Pa (l/s/m <sup>2</sup> )	0.22	0.63	1.90					
	Filter by-passed class	F9	F9	F9	F9	F8	F7	F <sup>^</sup>	G1-F5
Thermal Transmittance	Maximum by-pass leakage rate, k in % of the volume flow rate	0.5	1	2	4	6			
	Thermal Transmittance class	T2	T3	T4	T1	T2	T3	T4	T5
Thermal Bridging Factor	Heat transfer coefficient of the cabinet (U) W/(m <sup>2</sup> .K)	U≤0.5	0.6≤U ≤1.0	1.0≤U ≤1.4	1.4≤U ≤2.0	No requirement			
	Thermal bridging factor class	TB2	TB3	TB3	TB1	TB2	TB3	TB4	TB5
	Cold Bridge coefficient of the cabinet (Kb)	0.75≤Kb ≤1.0	0.6≤Kb ≤0.75	0.45≤Kb ≤0.6	0.3≤Kb ≤0.45	No requirement			

**Table 1**

### 3.4 COIL SECTION

Coil is installed such that unit casing enclose headers and return bends. Coil is designed based on the maximum utilization of available cross section area to achieve the most efficient heat transfer. Coil connections should be factory sealed with grommets on interior and exterior and gasket sleeve between outer wall and liner where each pipe extends through the unit casing to minimize air leakage and condensation inside panel assembly. Coils shall be removable through side and/ or top panels of unit without the need to remove and disassemble the entire section from the unit.

Coil constructed with aluminum corrugated fins and seamless copper tubes. Copper fins and hydrophilic fins are anti-corrosive materials which are optional. The fins are designed purposely for better heat transfer efficiency and moisture carry-over limit performance. Capacity, water pressure drop and selection procedure is designed in accordance with ARI Standard 410.

Cooling coils can be used when the face velocity does not exceed 2.5 m/s. For higher face velocity, a moisture eliminator is required to prevent condensate water carry over. For stacked coil in the coil section, drip pan is installed at back between coils to drain condensate to the main drain pans without flooding the lower coil section. The optional intermediate drain pan can be supplied for those needs to access for cleaning between the coils. Daikin Air Handling Units can handle both chilled water and direct expansion system.



**Figure 4: Water & DX System Coil**



**Figure 5: Stacked Coil**

### 3.5 DRAIN PAN

The deep and sloped drain pan is designed to discharge the condensate water quickly. It is fabricated by galvanized steel sheet protected with powder coating paint or stainless steel as option. Beneath the drain pan, it is covered with 10mm PE insulation to prevent any occurrence of condensation. For stacked coil, additional drip pan or intermediate drain pan fabricated from same material as main drain pan will be installed at back between two coils.



### 3.6 FACE AND BY PASS DAMPER

It consists of opposed blades varying air volume through the coil and by pass to attain the desired temperature. It provides very low leakage in the face and bypass sections. Face and bypass damper can be provided for temperature modulation by bypassing air around the coil. The damper blades are fabricated of aluminum and continuous Thermoplastic Elastomer (TPE) seals are inserted onto every damper blade. The rotated rod of handle is made of brass and handle is fabricated of aluminum casting. The size of damper is decided by the air flow volume ( $m^3/s$ ) and air speed ( $m/s$ ). The air speed go through the damper shall not exceed 7.5  $m/s$ .

### 3.7 FAN

Fans are used extensively in air-conditioning for circulating air over coils. The fan type includes forward, backward, airfoil wheel fan, twin fans with double width double inlet (DWDI) centrifugal fan. The first low cost option will be forward curved fans which are generally used for low static pressure applications. The blade of fan is constructed of galvanized steel. It consists of blade which has tips curving forward that is in the direction of rotation of fan wheel.

Meanwhile, for backward curve fans, it is run at higher speed and therefore has to be sturdier in construction. The blade of backward curved is made of heavy gauge steel or mild steel, painted after manufacturing. It can handle high static pressure system and able to show higher efficiency over a broader range of higher system resistance.

For airfoil fans, normally it will be the last option due to the costly components. It is constructed of mild steel. However, it shows higher efficiency, generate low noise level and can handle higher static pressures. Daikin housed air foil fans can operate up to 2240pa of static pressure.



Fan performance of all these fans have been tested and measured in accordance to AMCA Standard 210. The sound level is measure and rated in accordance with AMCA Standard 300. The fan bearing provided will have a minimum L50 life of 200,000 hours, and option available as high as 1,000,000 hours. Bearings are selected for minimum noise level and minimal device. The bearing is lubricated for life and maintenance free, lubrication is optional. Fan is dynamically and statically balanced to Standard ISO 1940. The fan shaft is manufactured from C45 carbon steel. It is coated with a layer of anti-corrosion varnish.

Fan discharges direction can be vertical (top & bottom) or horizontal discharge. The fan discharge should be square (for both forward and backward wheel fans) in area and flanged and isolated from the casing by the fire retardant grade flexible connection. Only one fan discharge is provided.

Fan selection requires accurate calculation of the air flow resistance through the whole system consisting of the total of two parts; external and internal static pressure. External static pressure is found in the distribution system, external to the air handler. Internal static pressure is the sum of the resistance of the coils and others component.

Beside, a comprehensive range of AC & EC plug fans is available to meet different design criteria. These fans are design to operate unboxed inside the AHUs. The flexible fan section provides a wide combination of discharge arrangements. Plenum fans also contribute to lower overall system pressure drop, thereby reducing energy consumption.

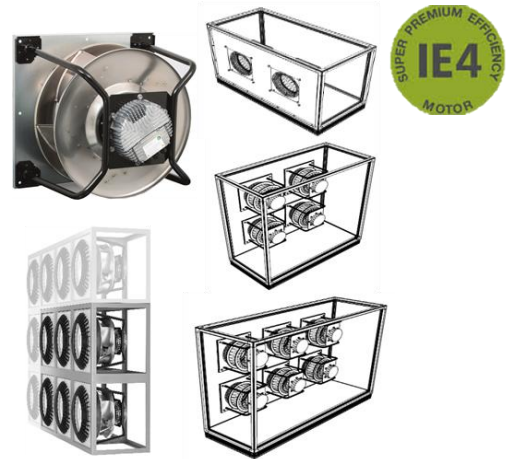

**Figure 6: AC plug fan & EC Plug Fan**

### 3.8 MOTOR

Motor is internally mounted integral to an isolated fan assembly. Standard motor shall be horizontal foot mounting, induction motor, squirrel cage, totally enclosed fan-cooled (TEFC) with IP 55 protection and class F insulation. Motor capacity cannot be undersized but oversized for desired running capacity. For the desired operation speed between fan and motor, different poles (2, 4, 6 and 8 poles) can be consider.

#### MOTOR OPTION

- 380-415 Volt / 3 phase/ 50 Hz ( standard)
- 220/230/380/460 Volt/ 3 phase/ 60Hz
- Motor efficiency from IE1, IE2, IE3 up to IE4 (EC motor)
- Dual speed motor
- Motor with space heater & Thermistor
- Explosion / Flame proof



**Figure 7: Induction Motor**

There are a few components which are able to provide safety, efficiency and flexibility feature for the operation of AHU. It includes thermistor, variable frequency drives (VFD), disconnect switch and others. When operating with VFD, frequency within 30 to 60 Hz is recommended for standard induction motor.

### 3.9 FAN / MOTOR ASSEMBLIES

Fan assemblies are easy to service provided with –

- The adjustable motor bases allow for proper tensioning of the belts at all times.
- Two-piece split belt guards
- The belt guard is fastened by bolt and nut via three clamps.



**Figure 8: Fan - Motor Assembly**

### 3.10 VIBRATION ISOLATOR

The fan in AHU can create substantial vibration that will transform to panels/ casing and consequently widespread the generated sound waves. To avoid this, the spring or rubber isolator is mounted between the fan compartment and the rest of the AHU to prevent the transmission of noise and vibration into panels.

There are two types of isolators used:

- Rubber mounting ( for blower <= model 355)
- 25mm deflection spring ( for blower > model 355)



Figure 9. Vibration Isolator

### 3.11 THERMISTOR

A thermistor is a type of resistor used to measure temperature changes in protection of windings in electric motors.

### 3.12 VFD/ FREQUENCY INVERTER

A VFD provides adjustable speed control of a single fan motor. Normally, an AHU which has been installed by VFD can vary the frequency within 30 to 60 Hz in order to control the motor rotation speed. It also provides protection for the motor operation.

### 3.13 ENERGY RECOVERY

#### 3.13.1 HEAT RECOVERY WHEEL

Introducing ventilation from outdoors is essential in maintaining desired indoor air quality. Heat wheel is available as the option to match this requirement. These energy components can recover 50% or more of the energy normally exhausted from a building. They are working based on this concept – capture heat from exhaust air as it passes through the air handling unit and transfer it to the supply air stream. Hence, it is able to reduce the cost of heating or cooling the outside air. During the winter, energy recovery components do this by transferring energy from a warm air stream to a colder air stream. On the other hand, during the summer, it is used to cool the air hot air.

It is constructed of aluminum coated with heat transfer material (silica gel or others) which is rotated by an electric motor at constant or variable speed. It is currently known as the most efficient technology.

There are two sections of fan required: exhaust fan and supply fan. The heat wheel rotates at a constant low speeds, capturing and transferring both sensible (heat) energy and latent (moisture) energy. The ability to transfer both sensible and latent energy gives the heat wheel several advantages. First, it can reduce the capacity of ventilation equipment. Furthermore, heat wheels can work at lower temperature without frosting occurs. The supply air from the heat wheel is not near saturation level, and moisture in the ductwork is not an issue. The benefit includes recover both latent and sensible heat by allowing reduction in system capacity about 30 to 65%. The most significant benefit is to prevent sick building syndrome.

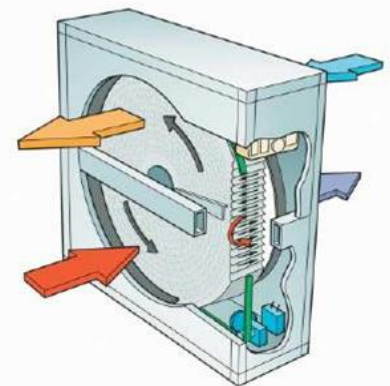

Figure 10: Heat Recover Wheel

### 3.13.2 HEAT PIPE

Heat pipe technology was founded in year 1982. It is a simple device that can transfer heat quickly from one point to another without requisite of energy input. The basic make up of heat pipe is just a metal tube (usually copper) sealed at both ends, evacuated to a vacuum and charged with refrigerant.

When one end of the pipe is exposed to warm air stream, the inside refrigerant absorbs heat and evaporates (as shown in A) and the vapor moves to the cooler end (as shown in B). As the vapor reaches to the condensing area of the cylinder (shown as C), the heat is given off to the environment and the vapor condenses. The liquid returns by gravity or capillary action. This will be a continuous cycle inside the heat pipe.

For conventional air conditioner, it uses up most cooling capacity to cool the air to dew point but less capacity for dehumidification. Meanwhile, air conditioner which is installed with heat pipe enhance air conditioner usage by allowing more cooling capacity to go towards latent cooling by pre-cooling air before it gets to cooling coil session. Only periodical cleaning is required for maintenance.

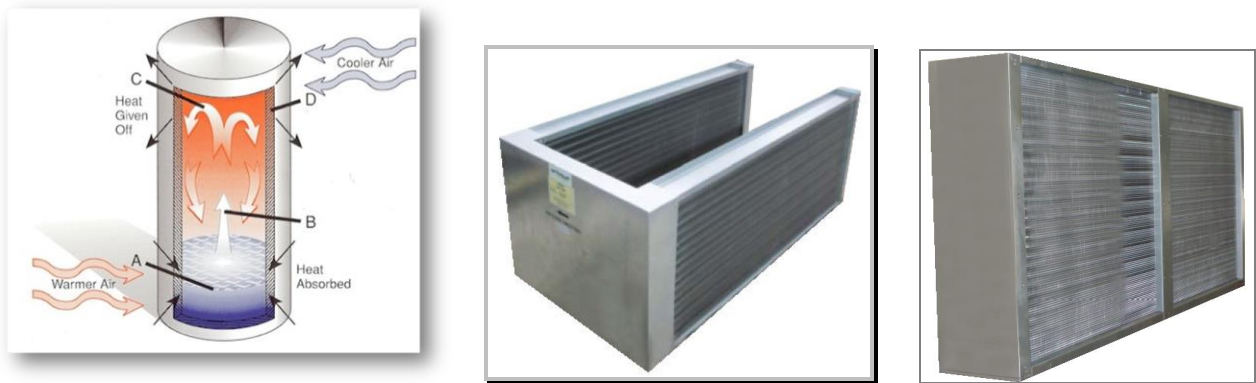

Figure 11: Heat Pipe (Wrap around Type & Straight Type)

### 3.13.3 Air to Air cross flow Plated Heat Exchanger (PHE).

Construct with corrugated aluminum fin to increase the turbulence and heat transfer without creating stagnation points, extruded aluminum corner profiles and aluzinc steel endplate frame. Complete assembly form a rigid, stable unit. Plate corners are sealed with MS polymer silicone free sealant and rated for air temperature up to 190 OF. Connecting plate edges are folded on automated manufacturing equipment. Adhesive in plate folds shall limit leakage to 0.1% at 1.6"W.C. differential pressure. Air leakage is defined as 0.1% of the rated airflow of the individual model.

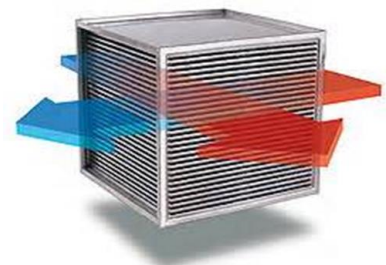

Figure 12: Plated Heat Exchanger

### 3.14 HUMIDIFIER

There are two type of humidifiers are used commercially in AHU. First is electrode steam humidifier, which is categorized isothermal type, the second, spray nozzle humidifier, which is adiabatic type. It requires an empty section to be installed. It is a device which is used to increase the air humidity ratio in atmosphere without steam source. It is a constant temperature humidifier. Its principle is the common electrode humidifier regulates the generated steam by the way of controlling water level and electrical current. Electrical loop will be built up through salt minerals in the water. Therefore, water will be heated up and boiled until vapor is generated continuously. Quality of water in the region must be considered because it reduces the steam capacity. (Softened water cannot be used).

### 3.15 ELECTRIC HEATER

It is used to achieve desired room condition at certain desired relative humidity. With negligible air pressure drop, accurate controllability, light weight, easy serviceability and inherent freeze protection, electrical heater is valuable alternatives to conventional steam and hot water heating coils.

Electric heaters are optional with either single step or multi step of heating process. It depends much on the heating capacity. Heaters are available in 220-240V and the wiring can be in single phase / 3 phase for contactor or thyristor control.



Figure 13. Electric Heater in AHU

### 3.16 FILTER SECTION

It plays a major role in maintaining good indoor air quality by filtration. There are a wide range of filter options which are provided by prominent filter manufacturer. The DM AHU has been designed to handle primary, secondary & HEPA filtration. Beside, activated carbon filters are available with designed to improve indoor air quality through the effective removal of indoor and outdoor gaseous contaminants typically found in the urban environment. This includes VOCs, SO<sub>x</sub>, NO<sub>x</sub>, and Ozone.



### 3.17 Quick Air Filter Selection Guide

#### Classification as per EN 779

EN 779 Class	G1	G2	G3	G4
Average Arrestance, Am%	Am < 65	65 ≤ Am ≤ 80	80 ≤ Am ≤ 90	90 ≤ Am
Recommended Filter	-	AmerTex R15	AmerTex R29 Aluminum Mesh	AmAir 300E AmerTex R50

**Table 2: Filter Arrestance for Coarse filters in Class G1-G4**

EN 779 Class	M5	M6	F7	F8	F9
Average Efficiency, Em%	40 ≤ Em ≤ 60	60 ≤ Em ≤ 80	80 ≤ Em ≤ 90	90 ≤ Em ≤ 95	95 ≤ Em
Recommended Filter	AmAir 500E	DriPak® 2000	DriPak® 2000 Varicel® II	DriPak® 2000 Varicel® II	DriPak® 2000 Varicel VXL

**Table 3: Filter Arrestance for fine filters in Class M5-F9**

#### Classification as per EN 1822

EN 1822 Class	E 10	E 11	H 13	H 14
Efficiency (% at 0.3µm)	> 95	> 98	> 99.997	> 99.999
Efficiency (% at MPPS)	> 85	> 95	> 99.95	> 99.995
Recommended Filter	BioCel® I	-	AstroCel®	AstroCel®

**Table 4: Filter Efficiency for EPA & HEPA Filters Class E10-H14**

In addition, filter section can be enhanced by an optional item – filter pressure gauge to ensure regular filter servicing and prevent clogging. Normally, the filter life span can be indicated by pressure gauge value.

### 3.18 MIXING BOX / DAMPER

It is an air inlet section to mix fresh and return air according to the system designer's requirement. It can regulate the amount of outside and return air supplied to the conditioned space. It consists of damper in parallel blades with opposed rotating blade with driving shaft. The damper blades are fabricated of aluminum and continuous Thermoplastic Elastomer (TPE) seals are inserted onto every damper blade. The rotated rod of handle is made of brass and handle is fabricated of aluminum casting. There are a few type of arrangement: top, rear and combination of top and rear. The mixing box can make use of free cooling by opening outside air dampers when the ambient air will help to condition the supply air stream. In addition, dampers maybe individually sized to provide better mixing effect.



**Figure 15. Damper & Mixing Box**

### 3.19 SOUND ATTENUATOR

It has a perimeter galvanized steel frame. Standard pods is supplied 100mm thick in standard lengths of 900 and 1200mm according to the attenuation required. The modular widths available are 275mm or 300mm.

Nowadays, sound level will be an essential factor to be considered as one of the performance of units. Daikin product has been designing to provide the quietest sound level. Different attenuator length can be selected to meet the most stringent sound attenuation requirements. A comfortable surrounding enhances human's working and living life.

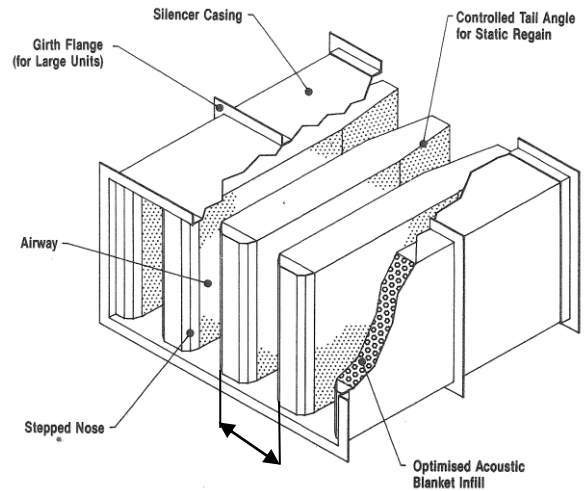

Figure 16. A Typical Cut Away View of sound

### 3.20 ULTRA VIOLET GERMICIDAL IRRADIATION (UVGI)



Figure 17. ULTRA VIOLET

Air Handling Unit Systems shall include Ultraviolet Emitters for eradicating germs harboring in cooling coils and drain pans. Ultraviolet Germicidal Irradiation (UVGI) Lamps shall be installed after the cooling coil and before the fan section, which is the dampest area and is most prone to microbial growth.

This is to eliminate the growth of surface microbial containments on coils, fins and drain pans.

UVGI Systems is constructed with an inner lamp made of soft glass and out shell made of Quartz glass (called Quartz Shield)

There are 3 main concern for greater kill rate for microbial containment, which are :

1. Time : The greater the exposure time (contact time between the contaminant & the UV source), the more UV energy can be delivered to the contaminant resulting in a greater Kill Rate.
2. Intensity: The greater the intensity (strength of the UV source), the more UV energy can be delivered to the contaminant resulting in a greater Kill Rate.
3. Distance: A "distance correction factor" may be needed when calculating a desired dose or intensity to a surface.

## 4.0 STANDARD UNITS QUICK SELECTION TABLE

**Table 5 : Return Air**

UNIT SIZE	Air Flow	ESP	4-ROWS COOLING COIL						1-ROW HEATING COIL				MOTOR kW
			S.C	T.C.C	Off Coil (°C)	Water flow	WPD	Circuit	T.C	Off Coil (°C)	Water flow	WPD	
			kW	kW	Dry/Wet	lps	kPa		kW	Dry/Wet	lps	kPa	
LPS	Pa												
<b>0404</b>	646	500	7.94	8.66	16.40/15.65	0.43	0.81	S	4.75	27.70/18.33	0.13	0.1	1.5
<b>0407</b>	1027	500	13.69	16.64	15.51/14.78	0.83	3.19	S	8.92	28.92/18.73	0.24	0.38	2.2
<b>0410</b>	1408	500	19.7	25.3	14.94/14.23	1.27	7.86	S	13.17	29.53/18.93	0.36	0.9	3
<b>0413</b>	1789	500	25.74	33.99	14.59/13.89	1.7	15.06	S	17.32	29.84/19.03	0.47	1.71	4
<b>0707</b>	1670	500	22.26	27.06	15.51/14.78	1.36	5.94	S	14.5	28.92/18.73	0.39	0.6	3
<b>0710</b>	2289	500	32.03	41.13	14.94/14.22	2.06	14.2	S	21.4	29.53/18.93	0.58	1.39	5.5
<b>0713</b>	2908	500	41.85	55.25	14.60/13.89	2.77	26.5	S	28.16	29.84/19.03	0.76	2.55	5.5
<b>0715</b>	3321	500	48.37	64.57	14.45/13.75	3.24	36.98	S	33.27	30.14/19.13	0.9	3.68	7.5
<b>1010</b>	3169	500	44.35	56.95	14.94/14.22	2.86	23.55	S	29.63	29.53/18.93	0.8	2.14	7.5
<b>1013</b>	4026	500	57.93	76.5	14.60/13.89	3.84	43.38	S	38.99	29.84/19.03	1.06	3.84	7.5
<b>1015</b>	4598	500	66.96	89.4	14.45/13.75	4.48	14.47	S	46.06	30.14/19.13	1.25	5.47	11
<b>1019</b>	5741	500	85.58	116.69	14.15/13.46	5.85	27.17	S	59.43	30.45/19.22	1.61	9.5	11
<b>1021</b>	6312	500	94.89	130.16	14.04/13.36	6.53	35.34	S	65.34	30.45/19.22	1.77	11.72	11
<b>1315</b>	5619	500	81.83	109.25	14.45/13.75	5.48	29.83	S	56.29	30.14/19.13	1.53	3.12	11
<b>1319</b>	7016	500	104.58	142.61	14.15/13.46	7.15	53.34	S	72.63	30.45/19.22	1.97	5.58	15
<b>1321</b>	7715	500	115.98	159.09	14.04/13.36	7.98	33.59	S	79.87	30.45/19.22	2.17	6.99	15
<b>1519</b>	7654	500	114.1	155.58	14.15/13.46	7.8	25.92	S	79.23	30.45/19.22	2.15	6.02	15
<b>1521</b>	8416	500	126.52	173.54	14.04/13.36	8.7	33.78	S	87.12	30.45/19.22	2.37	7.52	15
<b>1819</b>	9568	500	142.63	194.48	14.15/13.46	9.75	26.48	S	99.05	30.45/19.22	2.69	7.59	18.5
<b>1821</b>	10520	500	158.15	216.93	14.04/13.36	10.88	34.48	S	108.9	30.45/19.22	2.96	9.41	18.5
<b>1823</b>	11473	500	172.45	236.58	14.04/13.36	11.86	42.94	S	120.68	30.60/19.27	3.28	11.82	22
<b>1827</b>	13378	500	192.48	254.19	14.60/13.89	12.75	12.69	D	142.96	30.75/19.32	3.88	17.33	22
<b>2027</b>	14270	500	205.31	271.14	14.60/13.89	13.59	13.42	D	152.49	30.75/19.32	4.14	18.58	30
<b>2033</b>	17300	500	252.91	338.9	14.40/13.70	16.99	22.39	D	187.75	30.90/19.37	5.1	29.79	30
<b>2035</b>	18333	500	269.1	361.84	14.35/13.66	18.14	26.04	D	202.03	31.05/19.42	5.49	35.04	30
<b>2039</b>	20284	500	302.5	412.3	14.14/13.46	20.67	35.06	D	223.53	31.05/19.42	6.07	44.41	37
<b>2233</b>	19482	500	284.78	381.65	14.40/13.70	19.14	24.95	D	211.44	30.90/19.37	5.74	34	37
<b>2239</b>	22900												
<b>2539</b>	24800	500	341.39	465.47	14.15/13.46	23.34	39.03	D	252.35	31.05/19.42	6.85	50.61	37

Rated Condition :

For Cooling Coil: EDB = 27deg. C, EWB = 19.5 deg. C, EWT = 7 deg. C, LWT = 12deg. C

For Heating Coil: EDB = 21 deg. C, EWT = 60 deg. C, LWT = 50 deg. C

Remark : Above data rated base on DM AHU 4.3 patch 26 database version 4.3.20190228



**Table 6 : Fresh Air**

UNIT SIZE.	Air Flow	ESP	4-ROWS COOLING COIL						1-ROW HEATING COIL				MOTOR kW
			S.C	T.C.C	Off Coil (°C)	Water flow	WPD	Circuit	T.C	Off Coil (°C)	Water flow	WPD	
			kW	kW	Dry/Wet	lps	kPa		kW	Dry/Wet	lps	kPa	
<b>0404</b>	646	500	10.77	23.64	20.01/19.71	1.19	5.31	S	8.96	12.66/2.55	0.24	0.31	1.5
<b>0407</b>	1027	500	18.9	43.12	18.45/18.21	2.16	18.83	S	16.09	14.30/3.45	0.44	1.11	2.2
<b>0410</b>	1408	500	27.06	62.5	17.72/17.52	3.13	42.07	S	23.15	15.00/3.83	0.63	2.52	3
<b>0413</b>	1789	500	32.23	72.97	18.80/18.56	3.66	36.5	D	30.33	15.47/4.08	0.82	4.68	4
<b>0707</b>	1670	500	30.73	70.12	18.45/18.21	3.52	37.28	S	26.17	14.30/3.45	0.71	1.84	3
<b>0710</b>	2289	500	39.04	86.5	19.66/19.38	4.34	47.19	D	37.63	15.00/3.83	1.02	4.02	5.5
<b>0713</b>	2908	500	52.38	118.62	18.80/18.56	5.95	89.22	D	49.3	15.47/4.08	1.34	7.27	5.5
<b>0715</b>	3321	500	61.12	139.45	18.45/18.21	6.99	123.75	D	57.16	15.70/4.20	1.55	10.09	7.5
<b>1010</b>	3169	500	54.05	119.76	19.66/19.38	6	88.54	D	52.1	15.00/3.83	1.41	6.32	7.5
<b>1013</b>	4026	500	72.52	164.22	18.80/18.56	8.23	166.97	D	68.26	15.47/4.08	1.85	11.22	7.5
<b>1015</b>	4598	500	84.62	193.07	18.45/18.21	9.68	18.82	D	79.13	15.70/4.20	2.15	15.39	11
<b>1019</b>	5741	500	109.12	251.4	17.91/17.70	12.6	33.39	D	100.28	15.94/4.33	2.72	25.69	11
<b>1021</b>	6312	500	121.3	280.19	17.72/17.52	14.05	42.36	D	111.88	16.17/4.45	3.04	32.54	11
<b>1315</b>	5619	500	103.42	235.94	18.45/18.21	11.83	90.42	D	96.71	15.70/4.20	2.63	8.44	11
<b>1319</b>	7016	500	133.35	307.23	17.91/17.70	15.4	154.78	D	122.55	15.94/4.33	3.33	14.54	15
<b>1321</b>	7715	500	148.26	342.46	17.72/17.52	17.17	26.13	D	136.74	16.17/4.45	3.71	18.66	15
<b>1519</b>	7654	500	145.48	335.17	17.91/17.70	16.81	21.79	D	133.7	15.94/4.33	3.63	15.8	15
<b>1521</b>	8416	500	161.73	373.58	17.72/17.52	18.73	27.97	D	149.17	16.17/4.45	4.05	20.23	15
<b>1819</b>	9568	500	181.36	418.98	17.91/17.70	21.01	27.01	D	167.13	15.94/4.33	4.54	20.25	18.5
<b>1821</b>	10520	500	202.16	466.98	17.72/17.52	23.41	34.44	D	186.46	16.17/4.45	5.06	25.77	18.5
<b>1823</b>	11473	500	222.83	516.16	17.54/17.34	25.88	43.13	D	203.35	16.17/4.45	5.52	31.35	22
<b>1827</b>	13378	500	265.39	617.92	17.16/16.99	30.98	64.7	D	240.55	16.41/4.58	6.53	45.67	22
<b>2027</b>	14270	500	283.08	659.12	17.16/16.99	33.05	69.04	D	256.59	16.41/4.58	6.97	49.2	30
<b>2033</b>	17300	500	350.44	819.82	16.79/16.62	41.11	113.28	D	311.07	16.41/4.58	8.45	76.28	30
<b>2035</b>	18333	500	375.3	879.77	16.59/16.44	44.11	132.71	D	334.36	16.64/4.70	9.08	89.42	30
<b>2039</b>	20284	500	417.51	979.48	16.49/16.35	49.11	170.57	D	369.94	16.64/4.70	10.05	113.03	37
<b>2233</b>	19482	500	394.6	923.23	16.79/16.62	46.29	128.25	D	350.31	16.41/4.58	9.51	87.82	37
<b>2239</b>	22900	500	471.19	1105.81	16.50/16.35	55.44	192.86	D	417.65	16.64/4.70	11.34	129.97	37

Rated Condition :

For Cooling Coil: EDB = 35 deg. C, EWB = 28 deg. C, EWT = 7 deg. C, LWT = 12deg. C

For Heating Coil: EDB = 0 deg. C, EWT = 60 deg. C, LWT = 50 deg. C

Remark : Above data rated base on DM AHU 4.3 patch 26 database version 4.3.20190228



## 5.1b HORIZONTAL TYPICAL CONFIGURATION

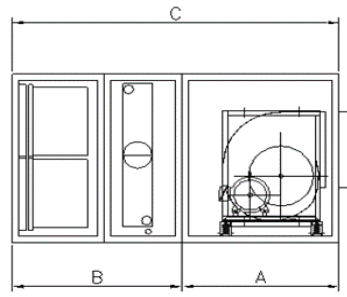

Type 3

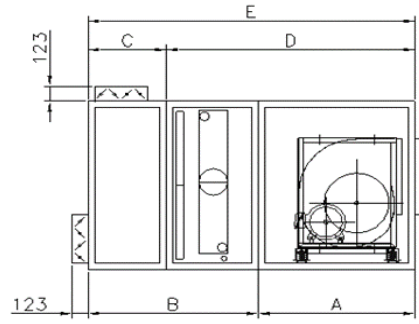

Type 4

Model	0404	0407	0410	0413	0707	0710	0713	0715	1010	1013	1015	1019	1021	1315	1319
CMH	2326	3697	5069	6440	6012	8240	10469	11956	11408	14494	16553	20668	22723	20228	25258
LPS	646	1027	1408	1789	1670	2289	2908	3321	3169	4026	4598	5741	6312	5619	7016
Height	800	800	800	800	1100	1100	1100	1100	1400	1400	1400	1400	1400	1700	1700
Width	800	1100	1400	1700	1100	1400	1700	1900	1400	1700	1900	2300	2500	1900	2300

### Length

3	A	900	900	1000	1000	1000	1000	1200	1200	1200	1200	1400	1400	1400	1400	1400
	B	1300	1300	1300	1300	1300	1300	1300	1300	1300	1300	1300	1300	1300	1300	1300
	C	2200	2200	2300	2300	2300	2300	2500	2500	2500	2500	2700	2700	2700	2700	2700
4	A	900	900	1000	1000	1000	1000	1200	1200	1200	1200	1400	1400	1400	1400	1400
	B	1300	1300	1300	1300	1300	1300	1300	1300	1300	1300	1300	1300	1300	1300	1300
	C	500	500	500	500	500	500	500	500	500	500	500	500	500	500	500
	D	1700	1700	1800	1800	1800	1800	2000	2000	2000	2000	2200	2200	2200	2200	2200
	E	2200	2200	2300	2300	2300	2300	2500	2500	2500	2500	2700	2700	2700	2700	2700

Model	1321	1519	1521	1819	1821	1823	1827	2027	2033	2035	2039	2233	2239	2539
CMH	27774	27554	30298	34445	37872	41303	48161	51372	62343	65999	73022	70135	82485	89406
LPS	7715	7654	8416	9568	10520	11473	13378	14270	17318	18333	20284	19482	22913	24835
Height	1700	1900	1900	2200	2200	2200	2200	2400	2400	2400	2400	2600	2600	2900
Width	2500	2300	2500	2300	2500	2700	3100	3100	3700	3900	4300	3700	4300	4300

### Length

3	A	1600	1600	1600	1600	1800	1800	2000	2000	2200	2200	2200	2200	2200 <sup>5)</sup>	2200 <sup>5)</sup>
	B	1300	1300	1300	1300	1300	1300	1300	1300	1300	1300	1300	1300	1300	1300
	C	2900	2900	2900	2900	3100	3100	3300	3300	3500	3500	3500	3500	3500	3500
4	A	1600	1600	1600	1600	1800	1800	2000	2000	2200	2200	2200	2200	2200 <sup>5)</sup>	2200 <sup>5)</sup>
	B	1300	1300	1300	1300	1300	1300	1300	1300	1300	1300	1300	1300	1300	1300
	C	500	500	500	500	500	500	500	500	500	500	500	500	500	500
	D	2400	2400	2400	2400	2600	2600	2800	2800	3000	3000	3000	3000	3000	3000
	E	2900	2900	2900	2900	3100	3100	3300	3300	3500	3500	3500	3500	3500	3500

**Table 8 : Horizontal Typical Configuration Type 3 & 4**

Note:

- 1) Please add 100mm for model using coil (8 Row & above)
- 2) The dimensions are subject to change without any notice for future improvement.
- 3) Dimensions in mm.
- 4) Please add 50mm length on the individual section width, depth and height if using the 50mm insulation panel.
- 5) For blower model 1250, section size will be 2600

## 5.1c HORIZONTAL TYPICAL CONFIGURATION

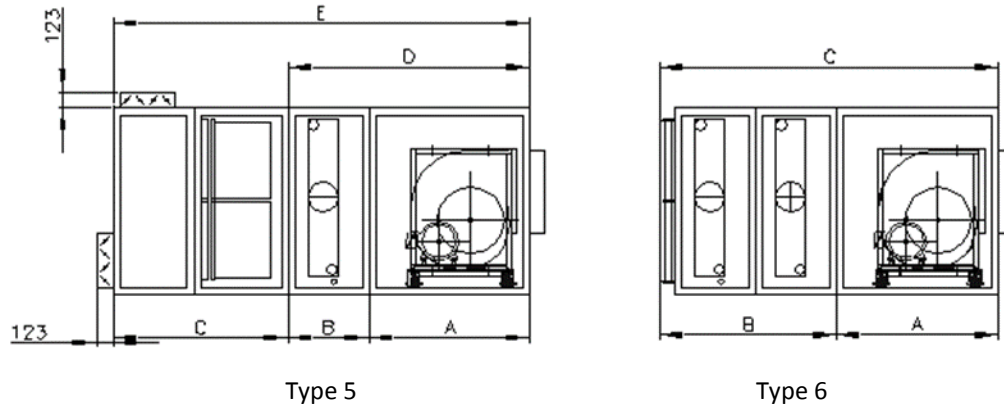

Model	0404	0407	0410	0413	0707	0710	0713	0715	1010	1013	1015	1019	1021	1315	1319
CMH	2326	3697	5069	6440	6012	8240	10469	11956	11408	14494	16553	20668	22723	20228	25258
LPS	646	1027	1408	1789	1670	2289	2908	3321	3169	4026	4598	5741	6312	5619	7016
Height	800	800	800	800	1100	1100	1100	1100	1400	1400	1400	1400	1400	1700	1700
Width	800	1100	1400	1700	1100	1400	1700	1900	1400	1700	1900	2300	2500	1900	2300

### Length

5	A	900	900	1000	1000	1000	1000	1200	1200	1200	1200	1400	1400	1400	1400	1400
	B	600	600	600	600	600	600	600	600	600	600	600	600	600	600	600
	C	1200	1200	1200	1200	1200	1200	1200	1200	1200	1200	1200	1200	1200	1200	1200
	D	1500	1500	1600	1600	1600	1600	1800	1800	1800	1800	2000	2000	2000	2000	2000
	E	2700	2700	2800	2800	2800	2800	3000	3000	3000	3000	3200	3200	3200	3200	3200
6	A	900	900	1000	1000	1000	1000	1200	1200	1200	1200	1400	1400	1400	1400	1400
	B	1300	1300	1300	1300	1300	1300	1300	1300	1300	1300	1300	1300	1300	1300	1300
	C	2200	2200	2300	2300	2300	2300	2500	2500	2500	2500	2700	2700	2700	2700	2700

Model	1321	1519	1521	1819	1821	1823	1827	2027	2033	2035	2039	2233	2239	2539
CMH	27774	27554	30298	34445	37872	41303	48161	51372	62343	65999	73022	70135	82485	89406
LPS	7715	7654	8416	9568	10520	11473	13378	14270	17318	18333	20284	19482	22913	24835
Height	1700	1900	1900	2200	2200	2200	2200	2400	2400	2400	2400	2600	2600	2900
Width	2500	2300	2500	2300	2500	2700	3100	3100	3700	3900	4300	3700	4300	4300

### Length

5	A	1600	1600	1600	1600	1800	1800	2000	2000	2200	2200	2200	2200	2200 <sup>5)</sup>	2200 <sup>5)</sup>
	B	600	600	600	600	600	600	600	600	600	600	600	600	600	600
	C	1200	1200	1200	1200	1200	1200	1200	1200	1200	1200	1200	1200	1200	1200
	D	2200	2200	2200	2200	2400	2400	2600	2600	2800	2800	2800	2800	2800	2800
	E	3400	3400	3400	3400	3600	3600	3800	3800	4000	4000	4000	4000	4000	4000
6	A	1600	1600	1600	1600	1800	1800	2000	2000	2200	2200	2200	2200	2200 <sup>5)</sup>	2200 <sup>5)</sup>
	B	1300	1300	1300	1300	1300	1300	1300	1300	1300	1300	1300	1300	1300	1300
	C	2900	2900	2900	2900	3100	3100	3300	3300	3500	3500	3500	3500	3500	3500

**Table 9 : Horizontal Typical Configuration Type 5 & 6**

Note:

- 1) Please add 100mm for model using coil (8 Row & above)
- 2) The dimensions are subject to change without any notice for future improvement.
- 3) Dimensions in mm.
- 4) Please add 50mm length on the individual section width, depth and height if using the 50mm insulation panel.
- 5) For blower model 1250, section size will be 2600

## 5.1d HORIZONTAL TYPICAL CONFIGURATION

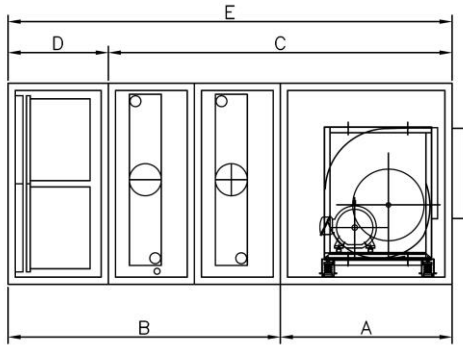

Type 7

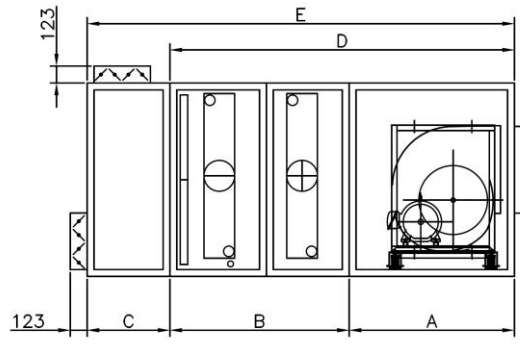

Type 8

Model	0404	0407	0410	0413	0707	0710	0713	0715	1010	1013	1015	1019	1021	1315	1319
CMH	2326	3697	5069	6440	6012	8240	10469	11956	11408	14494	16553	20668	22723	20228	25258
LPS	646	1027	1408	1789	1670	2289	2908	3321	3169	4026	4598	5741	6312	5619	7016
Height	800	800	800	800	1100	1100	1100	1100	1400	1400	1400	1400	1400	1700	1700
Width	800	1100	1400	1700	1100	1400	1700	1900	1400	1700	1900	2300	2500	1900	2300

### Length

7	A	900	900	1000	1000	1000	1000	1200	1200	1200	1200	1400	1400	1400	1400	1400
	B	1900	1900	1900	1900	1900	1900	1900	1900	1900	1900	1900	1900	1900	1900	1900
	C	2100	2100	2200	2200	2200	2200	2400	2400	2400	2400	2600	2600	2600	2600	2600
	D	700	700	700	700	700	700	700	700	700	700	700	700	700	700	700
	E	2800	2800	2900	2900	2900	2900	3100	3100	3100	3100	3300	3300	3300	3300	3300
8	A	900	900	1000	1000	1000	1000	1200	1200	1200	1200	1400	1400	1400	1400	1400
	B	1400	1400	1400	1400	1400	1400	1400	1400	1400	1400	1400	1400	1400	1400	1400
	C	500	500	500	500	500	500	500	500	500	500	500	500	500	500	
	D	2300	2300	2400	2400	2400	2400	2600	2600	2600	2600	2800	2800	2800	2800	2800
	E	2800	2800	2900	2900	2900	2900	3100	3100	3100	3100	3300	3300	3300	3300	3300

Model	1321	1519	1521	1819	1821	1823	1827	2027	2033	2035	2039	2233	2239	2539
CMH	27774	27554	30298	34445	37872	41303	48161	51372	62343	65999	73022	70135	82485	89406
LPS	7715	7654	8416	9568	10520	11473	13378	14270	17318	18333	20284	19482	22913	24835
Height	1700	1900	1900	2200	2200	2200	2200	2400	2400	2400	2400	2600	2600	2900
Width	2500	2300	2500	2300	2500	2700	3100	3100	3700	3900	4300	3700	4300	4300

### Length

7	A	1600	1600	1600	1600	1800	1800	2000	2000	2200	2200	2200	2200	2200 <sup>5)</sup>	2200 <sup>5)</sup>
	B	1900	1900	1900	1900	1900	1900	1900	1900	1900	1900	1900	1900	1900	1900
	C	2800	2800	2800	2800	3000	3000	3200	3200	3400	3400	3400	3400	3400	3400
	D	700	700	700	700	700	700	700	700	700	700	700	700	700	700
	E	3500	3500	3500	3500	3700	3700	3900	3900	4100	4100	4100	4100	4100	4100
8	A	1600	1600	1600	1600	1800	1800	2000	2000	2200	2200	2200	2200	2200 <sup>5)</sup>	2200 <sup>5)</sup>
	B	1400	1400	1400	1400	1400	1400	1400	1400	1400	1400	1400	1400	1400	1400
	C	500	500	500	500	500	500	500	500	500	500	500	500	500	
	D	3000	3000	3000	3000	3200	3200	3400	3400	3600	3600	3600	3600	3600	3600
	E	3500	3500	3500	3500	3700	3700	3900	3900	4100	4100	4100	4100	4100	4100

**Table 10 : Horizontal Typical Configuration Type 7&8**

Note:

- 1) Please add 100mm for model using coil (8 Row & above)
- 2) The dimensions are subject to change without any notice for future improvement.
- 3) Dimensions in mm.
- 4) Please add 50mm length on the individual section width, depth and height if using the 50mm insulation panel.
- 5) For blower model 1250, section size will be 2600

## 5.1e HORIZONTAL TYPICAL CONFIGURATION

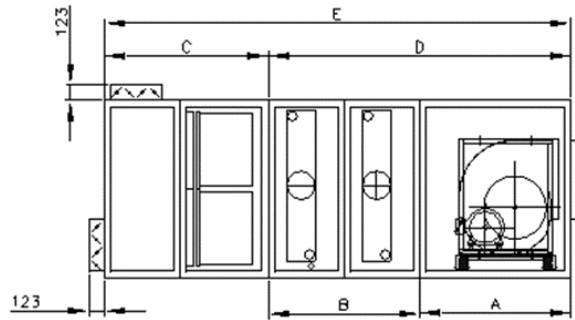

Type 9

Model	0404	0407	0410	0413	0707	0710	0713	0715	1010	1013	1015	1019	1021	1315	1319
CMH	2326	3697	5069	6440	6012	8240	10469	11956	11408	14494	16553	20668	22723	20228	25258
LPS	646	1027	1408	1789	1670	2289	2908	3321	3169	4026	4598	5741	6312	5619	7016
Height	800	800	800	800	1100	1100	1100	1100	1400	1400	1400	1400	1400	1700	1700
Width	800	1100	1400	1700	1100	1400	1700	1900	1400	1700	1900	2300	2500	1900	2300

### Length

9	A	900	900	1000	1000	1000	1000	1200	1200	1200	1200	1400	1400	1400	1400	1400	
	B	1200	1200	1200	1200	1200	1200	1200	1200	1200	1200	1200	1200	1200	1200	1200	1200
	C	1200	1200	1200	1200	1200	1200	1200	1200	1200	1200	1200	1200	1200	1200	1200	1200
	D	2100	2100	2200	2200	2200	2200	2400	2400	2400	2400	2600	2600	2600	2600	2600	2600
	E	3300	3300	3400	3400	3400	3400	3600	3600	3600	3600	3800	3800	3800	3800	3800	3800

Model	1321	1519	1521	1819	1821	1823	1827	2027	2033	2035	2039	2233	2239	2539
CMH	27774	27554	30298	34445	37872	41303	48161	51372	62343	65999	73022	70135	82485	89406
LPS	7715	7654	8416	9568	10520	11473	13378	14270	17318	18333	20284	19482	22913	24835
Height	1700	1900	1900	2200	2200	2200	2200	2400	2400	2400	2400	2600	2600	2900
Width	2500	2300	2500	2300	2500	2700	3100	3100	3700	3900	4300	3700	4300	4300

### Length

9	A	1600	1600	1600	1600	1800	1800	2000	2000	2200	2200	2200	2200	2200 <sup>5)</sup>	2200 <sup>5)</sup>
	B	1200	1200	1200	1200	1200	1200	1200	1200	1200	1200	1200	1200	1200	1200
	C	1200	1200	1200	1200	1200	1200	1200	1200	1200	1200	1200	1200	1200	1200
	D	2800	2800	2800	2800	3000	3000	3200	3200	3400	3400	3400	3400	3400	3400
	E	4000	4000	4000	4000	4200	4200	4400	4400	4600	4600	4600	4600	4600	4600

**Table 11 : Horizontal Typical Configuration Type 9**

Note:

- 1) Please add 100mm for model using coil (8 Row & above)
- 2) The dimensions are subject to change without any notice for future improvement.
- 3) Dimensions in mm.
- 4) Please add 50mm length on the individual section width, depth and height if using the 50mm insulation panel.
- 5) For blower model 1250, section size will be 2600

## 5.2a VERTICAL TYPICAL CONFIGURATION

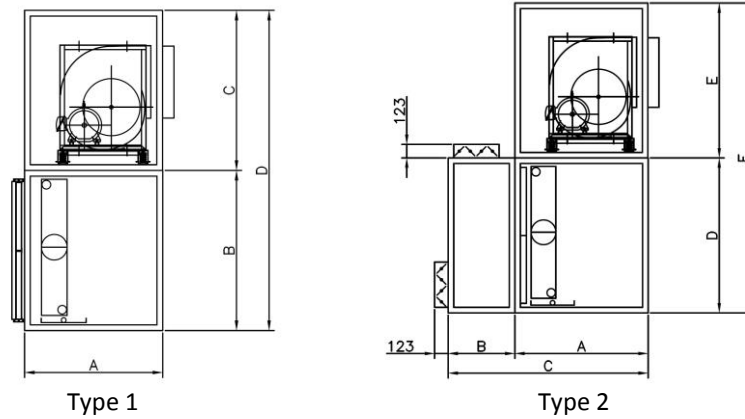

Model	0404	0407	0410	0413	0707	0710	0713	0715
CMH	2326	3697	5069	6440	6012	8240	10469	11956
LPS	646	1027	1408	1789	1670	2288	2908	3321
Width	800	1100	1400	1700	1100	1400	1700	1900

### Length

1	A	900	900	1000	1000	1000	1000	1200	1200
	B	800	800	800	800	1100	1100	1100	1100
	C	800	800	800	800	1100	1100	1100	1100
	D	1600	1600	1600	1600	2200	2200	2200	2200
2	A	900	900	1000	1000	1000	1000	1200	1200
	B	500	500	500	500	500	500	500	500
	C	1400	1400	1500	1500	1500	1500	1700	1700
	D	800	800	800	800	1100	1100	1100	1100
	E	800	800	800	800	1100	1100	1100	1100
F	1600	1600	1600	1600	2200	2200	2200	2200	

Model	1010	1013	1015	1019	1021	1315	1319	1321
CMH	11408	14494	16553	20668	22723	20228	25258	27774
LPS	3169	4026	4598	5741	6312	5619	7016	7715
Width	1400	1700	1900	2300	2500	1900	2300	2500

### Length

1	A	1200	1200	1400	1400	1400	1400	1400	1600
	B	1400	1400	1400	1400	1400	1700	1700	1700
	C	1100	1200	1200	1400	1400	1400	1600	1600
	D	2500	2600	2600	2800	2800	3100	3300	3300
2	A	1200	1200	1400	1400	1400	1400	1400	1600
	B	500	500	500	500	500	500	500	500
	C	1700	1700	1900	1900	1900	1900	1900	2100
	D	1400	1400	1400	1400	1400	1700	1700	1700
	E	1100	1200	1200	1400	1400	1400	1600	1600
F	2500	2600	2600	2800	2800	3100	3300	3300	

**Table 12 : Vertical Typical Configuration Type 1&2**

Note:

- 1) Please add 100mm for model using coil (8 Row & above)
- 2) The dimensions are subject to change without any notice for future improvement.
- 3) Dimensions in mm.
- 4) Please add 50mm length on the individual section width, depth and height if using the 50mm insulation panel.

## 5.2a VERTICAL TYPICAL CONFIGURATION

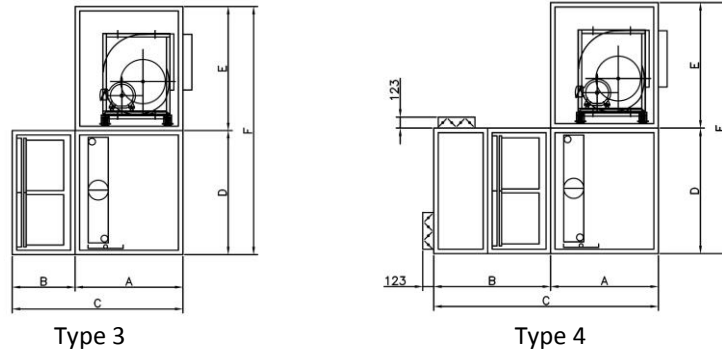

Model	0404	0407	0410	0413	0707	0710	0713	0715
CMH	2326	3697	5069	6440	6012	8240	10469	11956
LPS	646	1027	1408	1789	1670	2289	2908	3321
Width	800	1100	1400	1700	1100	1400	1700	1900

### Length

3	A	900	900	1000	1000	1000	1000	1200	1200
	B	700	700	700	700	700	700	700	700
	C	1600	1600	1700	1700	1700	1700	1900	1900
	D	800	800	800	800	1100	1100	1100	1100
	E	800	800	800	800	1100	1100	1100	1100
	F	1600	1600	1600	1600	2200	2200	2200	2200
4	A	900	900	1000	1000	1000	1000	1200	1200
	B	1200	1200	1200	1200	1200	1200	1200	1200
	C	2100	2100	2200	2200	2200	2200	2400	2400
	D	800	800	800	800	1100	1100	1100	1100
	E	800	800	800	800	1100	1100	1100	1100
	F	1600	1600	1600	1600	2200	2200	2200	2200

Model	1010	1013	1015	1019	1021	1315	1319	1321
CMH	11408	14494	16553	20668	22723	20228	25258	27774
LPS	3169	4026	4598	5741	6312	5619	7016	7715
Width	1400	1700	1900	2300	2500	1900	2300	2500

### Length

3	A	1200	1200	1400	1400	1400	1400	1400	1600
	B	700	700	700	700	700	700	700	700
	C	1900	1900	2100	2100	2100	2100	2100	2300
	D	1400	1400	1400	1400	1400	1700	1700	1700
	E	1100	1200	1200	1400	1400	1400	1600	1600
	F	2500	2600	2600	2800	2800	3100	3300	3300
4	A	1200	1200	1400	1400	1400	1400	1400	1600
	B	1200	1200	1200	1200	1200	1200	1200	1200
	C	2400	2400	2600	2600	2600	2600	2600	2800
	D	1400	1400	1400	1400	1400	1700	1700	1700
	E	1100	1200	1200	1400	1400	1400	1600	1600
	F	2500	2600	2600	2800	2800	3100	3300	3300

**Table 13 : Vertical Typical Configuration Type 3&4**

Note:

- 1) Please add 100mm for model using coil (8 Row & above)
- 2) The dimensions are subject to change without any notice for future improvement.
- 3) Dimensions in mm.
- 4) Please add 50mm length on the individual section width, depth and height if using the 50mm insulation panel.



## 6.0 APPLICATION CONSIDERATIONS

### 6.1 Installation Flexibility

Daikin AHU feature sectionalized design to provide maximum installation flexibility. Mixing box, filter, coil, fan and access components permit the design flexibility of built-up systems with the cost-effectiveness of factory fabricated units. Every section is fabricated of heavy-gauge continuous galvanized steel or extruded aluminum with exacting assembly procedures and rigid quality control standards.

### 6.2 Mounting and Access

Whether units are floor or ceiling mounted, care should be taken to ensure that the supporting structure is level and rigid enough for satisfactory unit operation. Ideally, a heavy concrete slab should be used for bottom mounted units, and main support beams for top hung units. Long floor or ceiling spans should be avoided.

Unit should be located so as to provide proper access for routine service. Clearance for filter removal on both sides of the filter section is usually necessary. Clearance should be provided as required for access panels. Room should be allowed for coil removal. Cooling units require clearance for a trap in the drain pan line.

Access to the interior of Daikin air handlers is provided by hinged access doors or removable panels wherever possible. For access between components, a versatile access section features hinged access doors at both ends.

### 6.3 Ductwork

Good ductwork layout will minimize system resistance and sound generation. Duct connections to and from units should allow straight, smooth airflow. Sharp turns in the fan discharge should be avoided, particularly turns opposed to wheel rotation. Turning vanes should be used. Discharge plenums or any abrupt change in duct should be avoided.

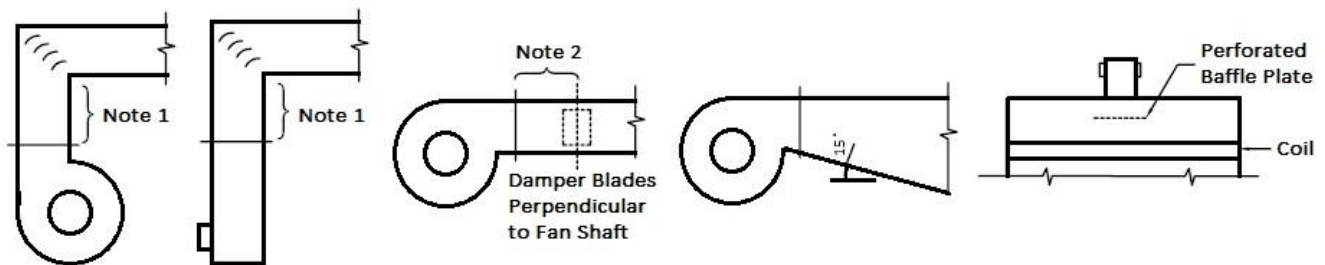

Figure 18: Discharge duct layout

- Notes: 1. Elbows should not be closer than 2 1/2 times duct diameter.  
2. Dampers should be placed at least fan diameters downstream of the fan discharge.

FIGURES REPRINTED WITH PERMISSION FROM THE 1979 ASHRAE GUIDE AND DATA BOOK (EQUIPMENT).

## 6.4 Piping and Drain Pan Traps

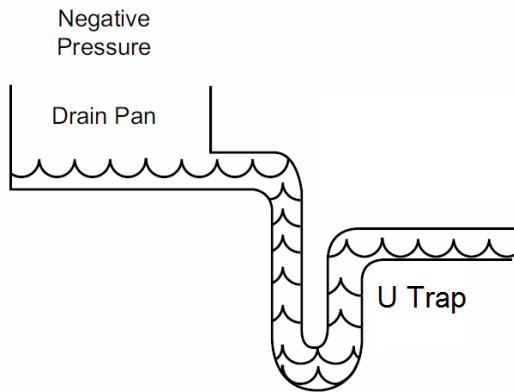

Figure 19: Drain pan traps

Piping should be in accordance with accepted industry standards. Undue stress should not be applied at the connection to coil headers. Pipe work should be supported independently of the coils with adequate piping flexibility for thermal expansion. Drain lines and traps should be run full size from the drain pan connection. Drain pans should have traps to permit the condensate from the coils to drain freely. On a draw-through unit, the trap depth and the distance between the trap outlet and the drain pan outlet should be twice the negative static pressure under normal unit operation. *Refer to IOM for details trap sizing.*

## 6.5 Air Supply Systems and Fan Laws

An air supply system consists of an AHU cabinet, heat exchanger, filters, ductwork, grilles and register used to distribute air throughout the building. The system is independent of the fan used to supply the system. The resistance of the system, referred to as static pressure (SP), is dependent upon the quantity of air (CFM) that is moved through it. The air quantity is determined by the cooling, heating and ventilating requirements.

For any system, the static pressure will vary directly as the square of the air quantity. This relationship between CFM and SP establishes the system curve for that system and may be expressed as follows:

$$\left(\frac{CFM_1}{CFM_2}\right)^2 = \frac{SP_1}{SP_2} \quad \text{or} \quad SP_2 = SP_1 \left(\frac{CFM_2}{CFM_1}\right)^2$$

The system curve is unique for a particular system configuration. Any change to the system caused by dirty filters, damper change, etc., will result in new system curve.

For fans operating at low pressures (less than 10" W.G.), the effects of air compression allows fan operation in a fixed system to be expressed by simple relationships. These relationships are known as fan laws and may be used to calculate the effects of fan speed and air density changes on this system.

1. The flow rate varies directly with the change in fan speed:

$$\frac{CFM_1}{CFM_2} = \frac{RPM_1}{RPM_2} \quad \text{or} \quad CFM_2 = CFM_1 \left(\frac{RPM_2}{RPM_1}\right)$$

A 10% increase in fan speed will give a 10% increase in air quantity.

2. The static pressure varies as the square of the change in fan speed:

$$\frac{SP_1}{SP_2} = \left(\frac{RPM_1}{RPM_2}\right)^2 \text{ or } SP_2 = SP_1 \left(\frac{RPM_2}{RPM_1}\right)^2$$

A 10% increase in fan speed will give a 21% increase in air static pressure.

3. The fan brake horsepower varies as the cube of the change in fan speed:

$$\frac{HP_1}{HP_2} = \left(\frac{RPM_1}{RPM_2}\right)^3 \text{ or } HP_2 = HP_1 \left(\frac{RPM_2}{RPM_1}\right)^3$$

A 10% increase in fan speed will give a 33% increase in fan horsepower.

4. System static pressure and brake horsepower are directly proportional to the air density:

$$SP_2 = SP_1 \left(\frac{Density_2}{Density_1}\right) \left(\frac{RPM_2}{RPM_1}\right)^2$$

$$HP_2 = HP_1 \left(\frac{Density_2}{Density_1}\right) \left(\frac{RPM_2}{RPM_1}\right)^3$$

Consequently, the static pressure and brake horsepower decrease with an increase in air temperature or higher altitude, and increase with a decrease in air temperature or lower altitude.

To determine fan performance for temperatures and altitudes other than standard (70°F, 0 ft. altitude), the static pressure must be adjusted by the density ratio before the fan RPM and BHP requirement can be determined. Density ratios are expressed as temperature and altitude conversion factors in Table 13.

AIR TEMP (°F)	ALTITUDE (FEET)								
	0	1000	2000	3000	4000	5000	6000	7000	8000
-20	1.20	1.16	1.12	1.08	1.04	1.00	0.97	0.93	0.89
0	1.15	1.10	1.08	1.02	0.99	0.95	0.92	0.88	0.85
20	1.11	1.06	1.02	0.98	0.95	0.92	0.88	0.85	0.82
40	1.06	1.02	0.98	0.94	0.91	0.88	0.84	0.81	0.78
60	1.02	0.98	0.94	0.91	0.88	0.85	0.81	0.79	0.76
70	1.00	0.96	0.93	0.89	0.86	0.83	0.80	0.77	0.74
80	0.98	0.94	0.91	0.88	0.84	0.81	0.78	0.75	0.72
100	0.94	0.91	0.88	0.84	0.81	0.78	0.75	0.72	0.70
120	0.92	0.88	0.85	0.81	0.78	0.76	0.72	0.70	0.67
140	0.89	0.85	0.82	0.79	0.76	0.73	0.70	0.68	0.65
160	0.85	0.82	0.79	0.76	0.74	0.70	0.68	0.65	0.63
200	0.80	0.77	0.75	0.72	0.69	0.67	0.64	0.62	0.60
250	0.75	0.72	0.69	0.67	0.65	0.62	0.60	0.58	0.56

**Table 14: Temperature and altitude conversion**

## 7.0 FAN SPECIFICATION

Model	Fan Section				Arrangement Units
	Available Fan Size	Discharge Size (mm)	Maximum Motor Size (kW)	Motor Mounting Position	R/RI/T/TI Discharge
					Depth (mm)
0404	180	230x230	3	Rear	900
	200	260x260	3	Rear	900
	225	295x295	4	Rear	900
0407	225	295x295	4	Rear	900
	250	330x330	4	Side	900
0410	250	330x330	7.5	Side	1000
	280	370x370	7.5	Side	1000
	315	410x410	7.5	Side	1000
0413	315	410x410	7.5	Side	1000
	355	460x460	7.5	Side	1000
0707	280	370x370	4	Side	1000
	315	410x410	2.2	Side	1000
0710	315	410x410	7.5	Side	1000
	355	460x460	7.5	Side	1000
0713	400	515x515	15	Side	1200
	450	575x575	11	Side	1200
0715	400	515x515	18.5	Side	1200
	450	575x575	18.5	Side	1200
1010	355	460x460	7.5	Side	1200
	400	515x515	7.5	Side	1200
1013	450	575x575	11	Side	1200
	500	645x645	7.5	Side	1200
1015	450	575x575	18.5	Side	1400
	500	645x645	30	Side	1400
1019	500	645x645	55	Side	1400
	560	720x720	55	Side	1400
	630	810x810	45	Side	1400
1021	560	720x720	55	Side	1400
	630	810x810	55	Side	1400
1315	500	645x645	30	Side	1400
	560	720x720	11	Side	1400
1319	560	720x720	35	Side	1400
	630	810x810	45	Side	1400
1321	560	720x720	55	Side	1600
	630	810x810	55	Side	1600
	710	910x910	55	Side	1600
1519	560	720x720	55	Side	1600
	630	810x810	45	Side	1600
1521	630	810x810	55	Side	1600
	710	910x910	55	Side	1600
1819	630	810x810	45	Side	1600
	710	910x910	22	Side	1600
1821	710	910x910	55	Side	1800
	800	1010x1010	30	Side	1800
1823	710	910x910	55	Side	1800
	800	1010x1010	55	Side	1800
1827	800	1010x1010	55	Side	2000
	900	1200x1200	55	Side	2000
	1000	1300x1300	55	Side	2000

Model	Fan Section				Arrangement Units
	Available Fan Size	Discharge Size mm	Maximum Motor Size kW	Motor Mounting Position	R/RI/T/TI Discharge
					Depth mm
2027	800	1010x1010	55	Side	2000
	900	1200x1200	55	Side	2000
	1000	1300x1300	55	Side	2000
2033	900	1200x1200	55	Side	2200
	1000	1300x1300	55	Side	2200
	1120	1430x1430	55	Side	2200
2035	900	1200x1200	55	Side	2200
	1000	1300x1300	55	Side	2200
	1120	1430x1430	55	Side	2200
2039	900	1200x1200	55	Side	2200
	1000	1300x1300	55	Side	2200
	1120	1430x1430	55	Side	2200
2233	900	1200x1200	55	Side	2200
	1000	1300x1300	55	Side	2200
	1120	1430x1430	55	Side	2200
2239	1000	1300x1300	55	Side	2200
	1120	1430x1430	55	Side	2200
	1250	1530x1530	55	Side	2600
2539	1120	1430x1430	55	Side	2200
	1250	1530x1530	55	Side	2600

**Table 15.**

# 7.1 FAN DISCHARGE ARRANGEMENT

Horizontal Arrangement Unit.

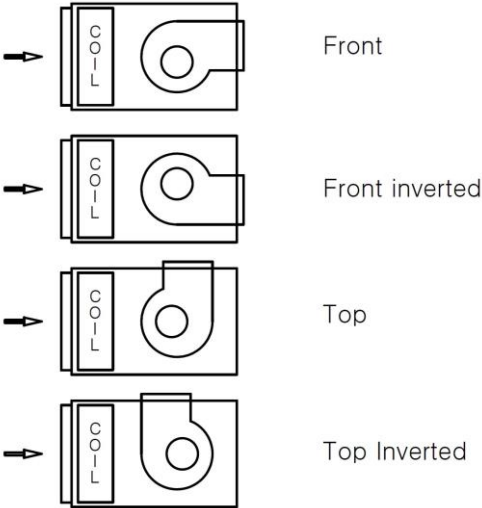

**Figure 20. Fan discharge orientation (Horizontal AHU)**

Vertical Arrangement Unit.

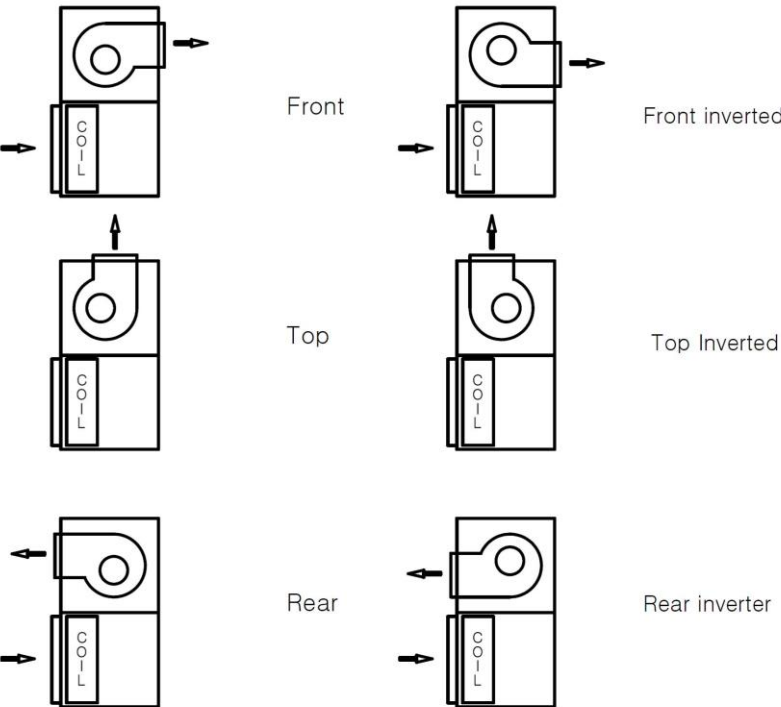

**Figure 21. Fan discharge orientation (Vertical AHU)**

## 8.0 FAN MOTOR SPECIFICATION

- Squirrel case induction motor is used for the DM Air Handling Unit. Motor is horizontal foot mounted, single speed and has a die case steel body.
- The motor shaft material is C-40 steel and the motor has Class F insulation with temperature limit of 145°C
- For motor below 4 kW, direct on line starting with 3 wire terminals only.  
For motor above 4 kW, star-delta starting with 6 wire terminals.
- Terminal box location is illustrated in Figure 22.

Terminal Box for Motor  
(View from shaft side)

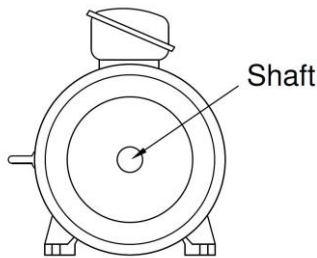

Figure 22.

### 4 POLES

Rated Power		Full Load Speed rev/min	Full Load Current at Rated	
kW	hp		415V	380V
0.55	0.75	1425	1.50	1.64
0.75	1	1425	1.88	2.05
1.1	1.5	1425	2.58	2.82
1.5	2	1425	3.34	3.64
2.2	3	1435	4.83	5.28
3	4	1445	6.02	6.58
4	5.5	1445	8.17	8.92
5.5	7.5	1465	11.0	12.0
7.5	10	1460	14.1	15.4
11	15	1465	20.2	22.1
15	20	1465	27.4	29.9
18.5	25	1475	33.5	36.6
22	30	1475	40.5	44.3
30	40	1475	53.2	58.1
37	50	1480	66.4	72.5
45	60	1475	79.8	87.2
55	75	1485	95.5	104
75	100	1480	133	145

Table 16.

### 6 POLES

Rated Power		Full Load Speed rev/min	Full Load Current at Rated	
kW	hp		415V	380V
0.55	0.75	915	1.57	1.72
0.75	1	935	2.10	2.29
1.1	1.5	935	3.09	3.35
1.5	2	935	3.70	4.04
2.2	3	950	5.36	5.85
3	4	965	7.22	7.89
4	5.5	960	8.82	9.63
5.5	7.5	965	12.8	14.0
7.5	10	960	15.1	16.5
11	15	965	21.7	23.7
15	20	970	29.0	31.7
18.5	25	975	35.2	38.5
22	30	975	41.8	45.7
30	40	975	53.8	58.8
37	50	975	66.3	72.4
45	60	980	83.0	90.7
55	75	980	99.7	109
75	100	985	133	146

Table 17.

## 9.0 BELT AND PULLEY SPECIFICATION

- DM Air Handling Unit comes standard with taper lock pulley and wedge belt with optional adjustable pulley and belt.
- Standard service factor of 1.5 suitable for 24 hours operation.

### 9.1 PULLEY ALIGNMENT

- Adjust the motor pulley to align with the fan pulley with the use of a straight edge.
- Do not force belts on the pulleys groove.
- Firstly, loosen the bolts at motor base until belt can slide smoothly over pulleys edge.
- When all the belts are in place, adjust belt tension at the adjusting nuts on the motor mount.
- Figure 23 illustrates the pulleys alignment.

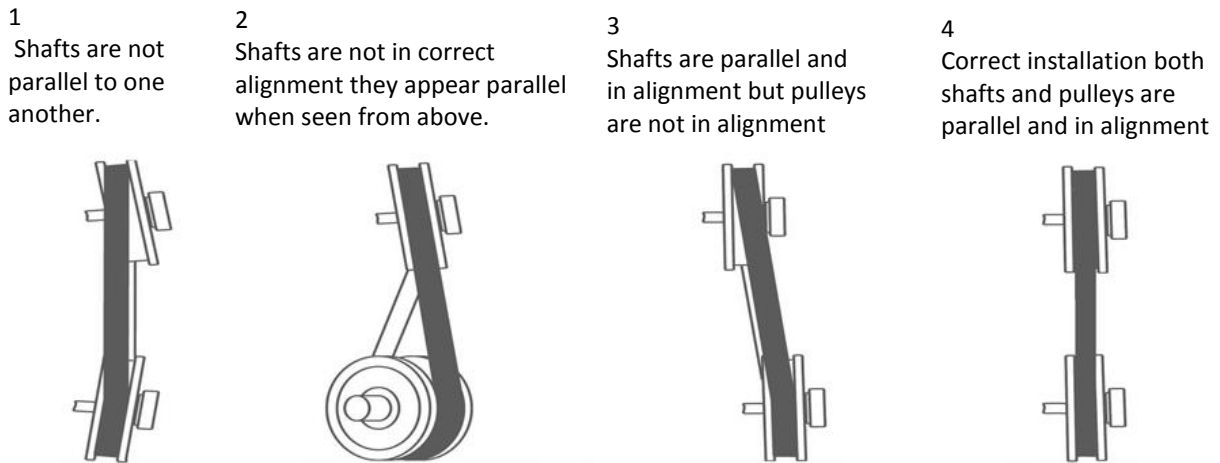

Figure 23

To check the belt tension, apply a force K large enough at the center of the belt to deflect the belt 15mm per meter. The deflection force for any belt should be within the minimum and maximum force shown in Table 18.

- When the tension drops to the minimum value, readjust to the maximum value.
- During normal operation a belt seat itself in pulleys grooves and require periodical checks to maintain tension.

**WARNING:** Improper pulleys alignment and belt tension are the most frequent causes of excessive vibration as well as shortened belt and bearing life. It is important to install the pulleys as close as practical to the bearing.

**CAUTION:** Do not over tighten the belts or the bearings may become damaged.

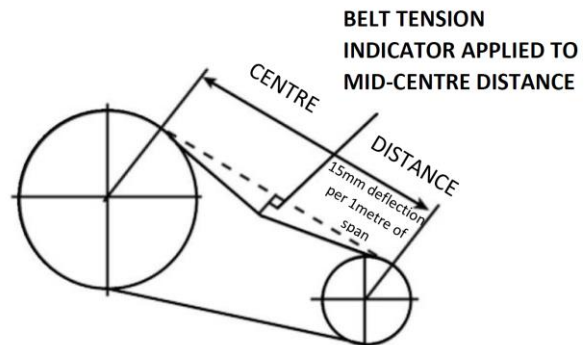

Figure 24



## 10.0 COIL SPECIFICATION

The DM Air Handling Units can be used for both chilled water system and direct expansion system application. Coils are designed based on application to best meet the requirements.

- Standard Aluminum fins are maximum 12 FPI (fin per inch). Copper fins are also available as option. Fin thickness is 0.115mm and fin hardness is H0 and H22 for standard aluminum fin and others fins respectively. Fins can be coated by Heresite or Hydrophilic fin material as a corrosion protective layer.
- Standard coil frame is in 1.5mm thick galvanized steel (GI) while stainless steel (SSTL) is available as an option when copper fin is used to avoid galvanization effect. Coil casing is designed to have drain holes at the bottom channels to ensure condensate drainage.
- For water system, the coil is available in 1, 2, 3, 4, 5, 6, 8, 10 and 12 rows. Header and collar is constructed of steel with copper material as the option. Its size is either 42 or 76 mm. Piping connection is only one sided, either “left” or “right”, viewing from return air side. The connection for steel header is by Male Pitch Threaded (MPT) joint. Copper header connection will be brazed joint type and optional for Male Pitch Threaded (MPT).

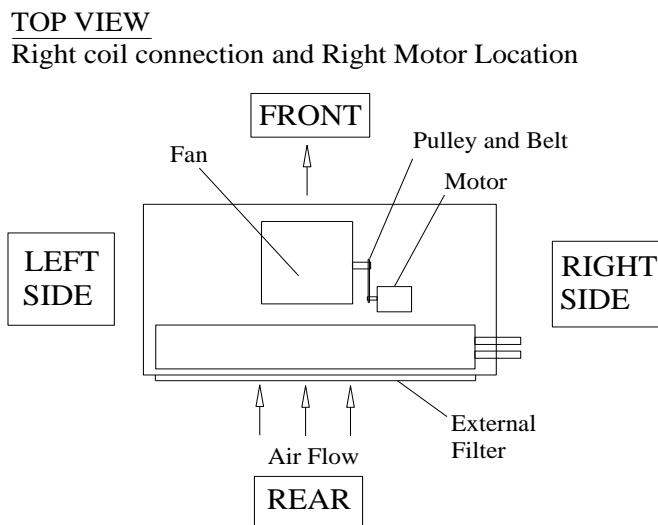

- For a direct expansion system, the coil is available in 2, 3, 4, 5, 6 and 8 rows. TXV valve is optional item. Header is only available in copper materials. Pipe connection is by brazing joint.
- The standard working pressure of the coil is 250 psig (17 bar). During fabrication, coil leak test are performed at pressure of 350 psig (24 bar).
- Coil surface area is standard size for each model and it is common for chilled water and direct expansion coil type. (Please refer Table 19.)

## 10.1 COIL SIZE AND FACE AREA

Model	Coil Size (1/2" copper tube)				Face Area	
	Fin Height		Fin Length			
	in	mm	in	mm	ft <sup>2</sup>	m <sup>2</sup>
<b>0404</b>	20	508	20.04	509	2.78	0.259
<b>0407</b>	20	508	31.85	809	4.42	0.411
<b>0410</b>	20	508	43.66	1109	6.06	0.563
<b>0413</b>	20	508	55.47	1409	7.70	0.716
<b>0707</b>	32.5	825.5	31.85	809	7.19	0.668
<b>0710</b>	32.5	825.5	43.66	1109	9.85	0.915
<b>0713</b>	32.5	825.5	55.47	1409	12.52	1.163
<b>0715</b>	32.5	825.5	63.35	1609	14.30	1.328
<b>1010</b>	45	1143	43.66	1109	13.64	1.268
<b>1013</b>	45	1143	55.47	1409	17.34	1.610
<b>1015</b>	45	1143	63.35	1609	19.80	1.839
<b>1019</b>	45	1143	79.09	2009	24.72	2.296
<b>1021</b>	45	1143	86.97	2209	27.18	2.525
<b>1315</b>	55	1397	63.35	1609	24.19	2.248
<b>1319</b>	55	1397	79.09	2009	30.21	2.807
<b>1321</b>	55	1397	86.97	2209	33.22	3.086
<b>1519</b>	60	1524	79.09	2009	32.96	3.062
<b>1521</b>	60	1524	86.97	2209	36.24	3.367
<b>1819</b>	75	1905	79.09	2009	41.20	3.827
<b>1821</b>	75	1905	86.97	2209	45.30	4.208
<b>1823</b>	75	1905	94.84	2409	49.40	4.589
<b>1827</b>	75	1905	110.59	2809	57.60	5.351
<b>2027</b>	80	2032	110.59	2809	61.44	5.708
<b>2033</b>	80	2032	134.21	3409	74.56	6.927
<b>2035</b>	80	2032	142.09	3609	78.93	7.333
<b>2039</b>	80	2032	157.83	4009	87.68	8.146
<b>2233</b>	90	2286	134.21	3409	83.88	7.793
<b>2239</b>	90	2286	157.83	4009	98.65	9.165
<b>2539</b>	97.5	2478	157.83	4009	106.93	9.934

Table 18

## 10.2 HEADER SIZE

Model	0404	0407	0410	0413	0707	0710	0713	0715	1010
Row									
1	42	42	42	42	42	42	42	42	42
2	42	42	42	42	42	42	42	42	42
3	42	42	42	42	42	42	42	42	42
4	42	42	42	42	42	42	42	42	42
5	42	42	42	42	42	42	42	42	42
6	42	42	42	42	42	42	42	42	76
8	42	42	42	42	42	42	42	42	76
10	76	76	76	76	76	76	76	76	76
12	76	76	76	76	76	76	76	76	76

Table 19a: dimension in mm

Model	1013	1015	1019	1021	1315	1319	1321	1519	1521	1819
Row										
1	42	42	42	42	42	42	42	42	42	42
2	42	42	42	42	42	42	42	42	42	42
3	42	42	42	76	42	42	42	42	42	76
4	42	76	76	76	42	42	76	76	76	76
5	42	76	76	76	42	42	76	76	76	76
6	76	76	76	76	76	76	76	76	76	76
8	76	76	76	76	76	76	76	76	76	76
10	76	76	76	76	76	76	76	76	76	76
12	76	76	76	76	76	76	76	76	76	76

Table 19b: dimension in mm

Model	1821	1823	1827	2027	2033	2035	2039	2233	2239	2539
Row										
1	42	42	42	42	42	42	42	42	42	42
2	42	42	42	42	42	42	42	42	42	42
3	76	76	76	76	76	76	76	76	76	76
4	76	76	76	76	76	76	76	76	76	76
5	76	76	76	76	76	76	76	76	76	76
6	76	76	76	76	76	76	76	76	76	76
8	76	76	76	76	76	76	76	76	76	76
10	76	76	76	76	76	76	76	76	76	76
12	76	76	76	76	76	76	76	76	76	76

Table 19c: dimension in mm

Above header size is selected based on condition of

EDB/EWB      26.7/19.4°C  
 EWT/LWT      7/12°C

### 10.3a HEADER LOCATION – SINGLE COIL

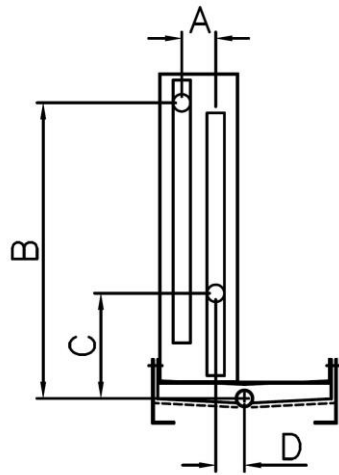

RIGHT HEADER

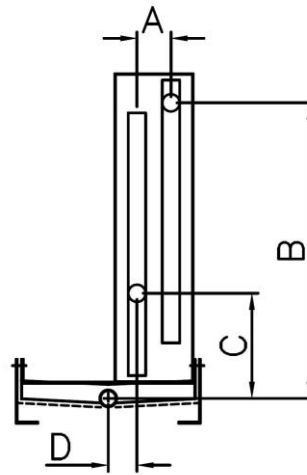

LEFT HEADER

1 ROW						
Model	TH	FH	A	B	C	D
04xx	16	508	55	516	106	129
07xx	26	825.5	55	834	256	129
10xx	36	1143	55	1151	256	129

6 ROW						
Model	TH	FH	A	B	C	D
04xx	16	508	137.5	530	106	26
07xx	26	825.5	137.5	848	256	26
10xx	36	1143	137.5	1165	256	26

2 ROW						
Model	TH	FH	A	B	C	D
04xx	16	508	55	530	106	115
07xx	26	825.5	55	848	256	115
10xx	36	1143	55	1165	256	115

8 ROW						
Model	TH	FH	A	B	C	D
04xx	16	508	192.5	530	106	37
07xx	26	825.5	192.5	848	256	37
10xx	36	1143	192.5	1165	256	37

3 ROW						
Model	TH	FH	A	B	C	D
04xx	16	508	55	530	106	84
07xx	26	825.5	55	848	256	84
10xx	36	1143	55	1165	256	84

10 ROW						
Model	TH	FH	A	B	C	D
04xx	16	508	247.5	530	106	24
07xx	26	825.5	247.5	848	256	24
10xx	36	1143	247.5	1165	256	24

4 ROW						
Model	TH	FH	A	B	C	D
04xx	16	508	82.5	530	106	70
07xx	26	825.5	82.5	848	256	70
10xx	36	1143	82.5	1165	256	70

12 ROW						
Model	TH	FH	A	B	C	D
04xx	16	508	302.5	530	106	80
07xx	26	825.5	302.5	848	256	80
10xx	36	1143	302.5	1165	256	80

5 ROW						
Model	TH	FH	A	B	C	D
04xx	16	508	110	530	106	39.5
07xx	26	825.5	110	848	256	39.5
10xx	36	1143	110	1165	256	39.5

Table 20a: Dimension in mm.

### 10.3b HEADER LOCATION – 2 LAYER COIL

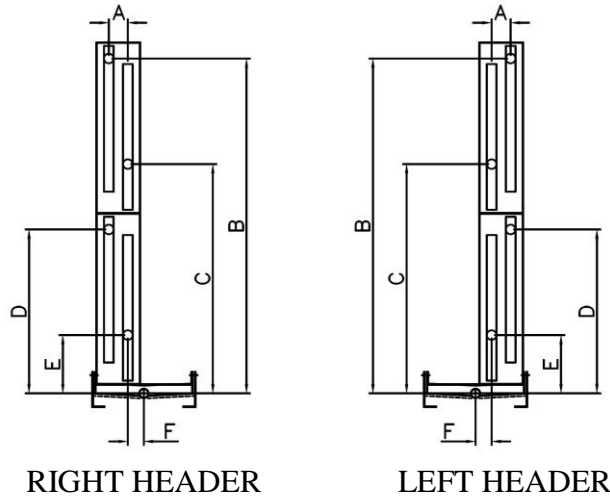

1 ROW								
Model	TH	FH	A	B	C	D	E	F
13xx	22	698.5	55	1455	1004	707	256	129
15xx	24	762	55	1582	1067.5	770.5	256	129
18xx	30	952.5	55	1963	1258	961	256	129
20xx	32	1016	55	2090	1321.5	1024.5	256	129
22xx	36	1143	55	2344	1448.5	1151.5	256	129

2 ROW								
Model	TH	FH	A	B	C	D	E	F
13xx	22	698.5	55	1471	1005	721	255	115
15xx	24	762	55	1598	1068	785	255	115
18xx	30	952.5	55	1979	1258	976	255	115
20xx	32	1016	55	2105	1321	1039	255	115
22xx	36	1143	55	2360	1449	1166	255	115

3 ROW								
Model	TH	FH	A	B	C	D	E	F
13xx	22	698.5	55	1471	1005	721	255	84
15xx	24	762	55	1598	1068	785	255	84
18xx	30	952.5	82.5	1979	1258	976	255	56
20xx	32	1016	82.5	2105	1321	1039	255	56
22xx	36	1143	82.5	2360	1449	1166	255	56

4 ROW								
Model	TH	FH	A	B	C	D	E	F
13xx	22	698.5	82.5	1471	1005	721	255	70
15xx	24	762	82.5	1598	1068	785	255	70
18xx	30	952.5	82.5	1979	1258	976	255	70
20xx	32	1016	82.5	2105	1321	1039	255	70
22xx	36	1143	82.5	2360	1449	1166	255	70

5 ROW								
Model	TH	FH	A	B	C	D	E	F
13xx	22	698.5	110	1471	1005	721	255	39.5
15xx	24	762	110	1598	1068	785	255	39.5
18xx	30	952.5	110	1979	1258	976	255	39.5
20xx	32	1016	110	2105	1321	1039	255	39.5
22xx	36	1143	110	2360	1449	1166	255	39.5

6 ROW								
Model	TH	FH	A	B	C	D	E	F
13xx	22	698.5	137.5	1471	1005	721	255	26
15xx	24	762	137.5	1598	1068	785	255	26
18xx	30	952.5	137.5	1979	1258	976	255	26
20xx	32	1016	137.5	2105	1321	1039	255	26
22xx	36	1143	137.5	2360	1449	1166	255	26

8 ROW								
Model	TH	FH	A	B	C	D	E	F
13xx	22	698.5	192.5	1471	1005	721	255	37
15xx	24	762	192.5	1598	1068	785	255	37
18xx	30	952.5	192.5	1979	1258	976	255	37
20xx	32	1016	192.5	2105	1321	1039	255	37
22xx	36	1143	192.5	2360	1449	1166	255	37

10 ROW								
Model	TH	FH	A	B	C	D	E	F
13xx	22	698.5	247.5	1471	1005	721	255	24
15xx	24	762	247.5	1598	1068	785	255	24
18xx	30	952.5	247.5	1979	1258	976	255	24
20xx	32	1016	247.5	2105	1321	1039	255	24
22xx	36	1143	247.5	2360	1449	1166	255	24

12 ROW								
Model	TH	FH	A	B	C	D	E	F
13xx	22	698.5	302.5	1471	1005	721	255	80
15xx	24	762	302.5	1598	1068	785	255	80
18xx	30	952.5	302.5	1979	1258	976	255	80
20xx	32	1016	302.5	2105	1321	1039	255	80
22xx	36	1143	302.5	2360	1449	1166	255	80

**Table 20b: Dimension in mm.**

### 10.3c HEADER LOCATION – 3 LAYER COIL

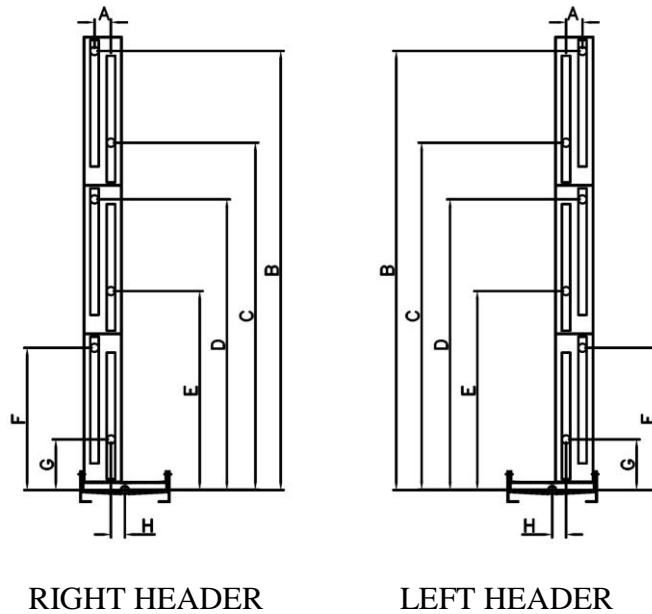

Model 2539								
26 TH (825.5 mmFH)								
ROW	A	B	C	D	E	F	G	H
1 ROW	55	2585	2007	1709	1131	834	256	129
2 ROW	55	2600	2007	1724	1131	848	255	115
3 ROW	110	2600	2007	1724	1131	848	255	56
4 ROW	82.5	2605	2012	1728	1135	848	255	70
5 ROW	110	2605	2012	1728	1135	848	255	39.5
6 ROW	137.5	2605	2012	1728	1135	848	255	26
8 ROW	192.5	2605	2012	1728	1135	848	255	37
10 ROW	247.5	2605	2012	1728	1135	848	255	24
12 ROW	302.5	2605	2012	1728	1135	848	255	80

**Table 20c: Dimension in mm.**

## 11.0 HEAT RECOVERY WHEEL SPECIFICATION

Heat recovery wheel is available in DM AHU selection software. AHU with HRW consists of two sections: return air side and supply air side. The arrangement is as below. To install the heat wheel in air handling unit, an empty section is required. The size of heat wheel has to be considered for the specification drawing. Besides, spaces between heat wheel section and the coil section must be considered to ensure the most efficient heat transfer between air flow and coil medium at the coil section beside the access for maintenance.

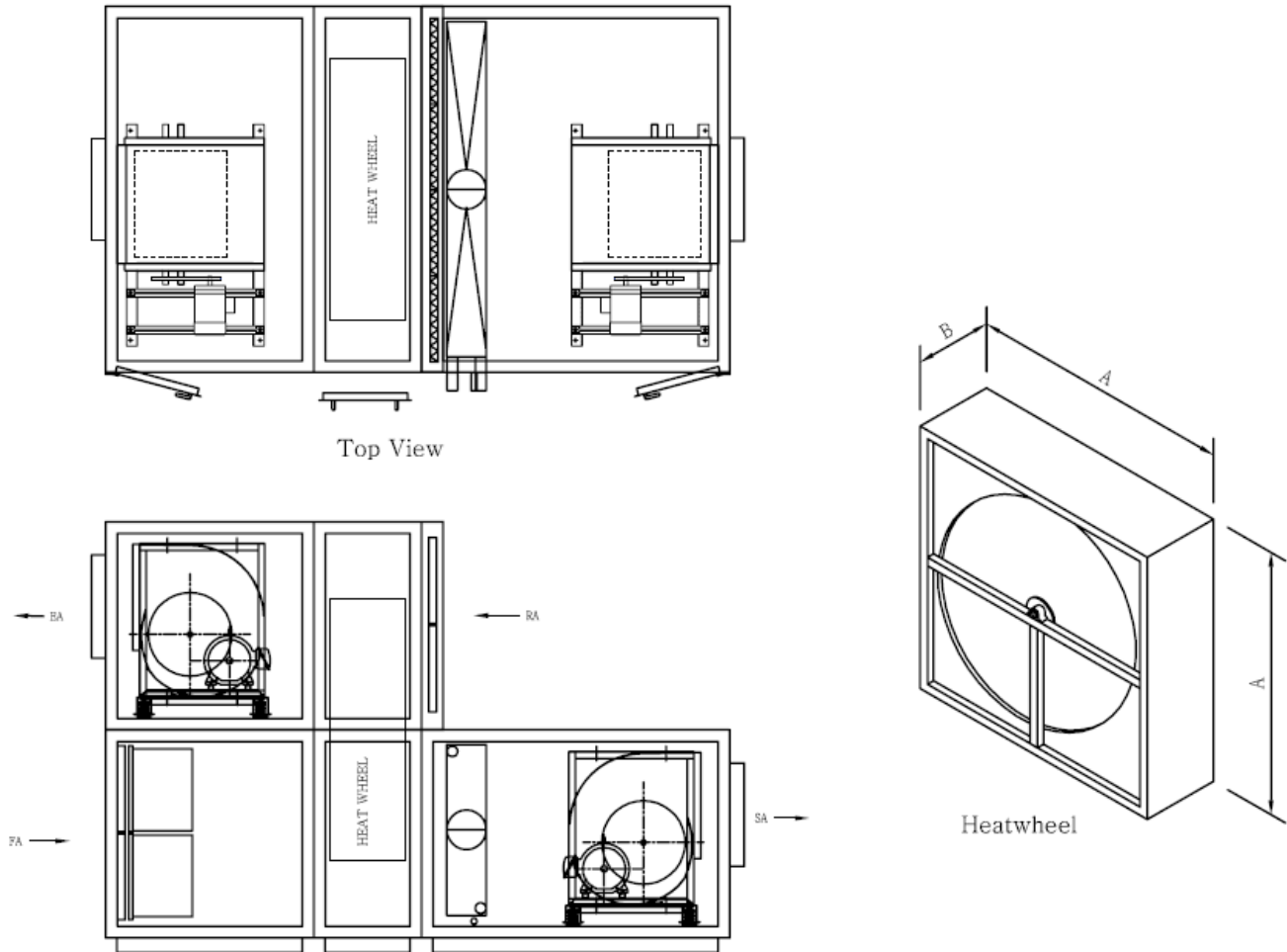

Figure 26



# 12.0 FILTER

## 12.1 Standard Filter Specification

Model	Filter Media Size and Quantity									
	Sliding Filter Frame					Universal Filter Frame				
	24" x 24"		24" x 12"		Total Area(m <sup>2</sup> )	24" x 24"		24" x 12"		Total Area (m <sup>2</sup> )
	Qty	Area (m <sup>2</sup> )	Qty	Area (m <sup>2</sup> )		Qty	Area (m <sup>2</sup> )	Qty	Area (m <sup>2</sup> )	
0404	1	0.37	0	0.00	0.37	1	0.37	0	0.00	0.37
0407	1	0.37	1	0.19	0.56	1	0.37	1	0.19	0.56
0410	2	0.74	0	0.00	0.74	2	0.74	0	0.00	0.74
0413	2	0.74	1	0.19	0.93	2	0.74	1	0.19	0.93
0707	1	0.37	2	0.37	0.74	1	0.37	2	0.37	0.74
0710	2	0.74	2	0.37	1.11	2	0.74	2	0.37	1.11
0713	2	0.74	3	0.56	1.30	2	0.74	3	0.56	1.30
0715	3	1.11	3	0.56	1.67	2	0.74	3	0.56	1.30
1010	4	1.49	0	0.00	1.49	4	1.49	0	0.56	1.49
1013	4	1.49	2	0.37	1.86	4	1.49	2	0.37	1.86
1015	6	2.23	0	0.00	2.23	4	1.49	2	0.37	1.86
1019	6	2.23	2	0.37	2.60	6	2.23	2	0.37	2.60
1021	8	2.97	0	0.00	2.97	6	2.23	2	0.37	2.60
1315	6	2.23	3	0.56	2.79	4	1.49	4	0.74	2.23
1319	6	2.23	5	0.93	3.16	6	2.23	5	0.93	3.16
1321	8	2.97	4	0.74	3.71	6	2.23	5	0.93	3.16
1519	6	2.23	5	0.93	3.16	6	2.23	5	0.93	3.16
1521	8	2.97	4	0.74	3.71	6	2.23	5	0.93	3.16
1819	9	3.34	3	0.56	3.90	9	3.34	3	0.56	3.90
1821	12	4.46	0	0.00	4.46	9	3.34	3	0.56	3.90
1823	12	4.46	0	0.00	4.46	12	4.46	0	0.00	4.46
1827	15	5.57	0	0.00	5.57	12	4.46	3	0.56	5.02
2027	15	5.57	5	0.93	6.50	12	4.46	7	1.3	5.76
2033	18	6.69	6	1.11	7.80	15	5.57	8	1.49	7.06
2035	18	6.69	6	1.11	7.80	18	6.69	6	1.11	7.8
2039	21	7.80	7	1.30	9.10	18	6.69	9	1.67	8.36
2233	24	8.92	0	0.00	8.92	20	7.43	4	0.74	8.18
2239	28	10.41	0	0.00	10.41	24	8.92	4	0.74	9.66
2539	28	10.41	7	1.30	11.71	24	8.92	10	1.86	10.78

Table 21.

## 12.2 HEPA FILTER SPECIFICATION

Model	HEPA Filter Size c/w Frame and Quantity/unit					
	Size : 24" x 24"		Size : 24" x 12"		Total	
	Qty	Area (m <sup>2</sup> )	Qty	Area (m <sup>2</sup> )	Qty	Area (m <sup>2</sup> )
0404	1	0.37	0	0.00	1	0.37
0407	1	0.37	1	0.19	2	0.56
0410	2	0.74	0	0.00	2	0.74
0413	2	0.74	0	0.00	2	0.74
0707	1	0.37	2	0.37	3	0.74
0710	2	0.74	2	0.37	4	1.11
0713	2	0.74	2	0.37	4	1.11
0715	2	0.74	3	0.56	5	1.30
1010	4	1.49	0	0.00	4	1.49
1013	4	1.49	0	0.00	4	1.49
1015	4	1.49	2	0.37	6	1.86
1019	6	2.23	0	0.00	6	2.23
1021	6	2.23	2	0.37	8	2.60
1315	4	1.49	2	0.37	6	1.86
1319	6	2.23	0	0.00	6	2.23
1321	6	2.23	2	0.37	8	2.60
1519	6	2.23	3	0.56	9	2.79
1521	6	2.23	5	0.93	11	3.16
1819	9	3.34	0	0.00	9	3.34
1821	9	3.34	3	0.56	12	3.90
1823	12	4.46	0	0.00	12	4.46
1827	12	4.46	3	0.56	15	5.02
2027	12	4.46	7	1.30	19	5.76
2033	15	5.57	8	1.49	23	7.06
2035	15	5.57	8	1.49	23	7.06
2039	18	6.69	6	1.11	24	7.8
2233	15	5.57	8	1.49	23	7.06
2239	18	6.69	6	1.11	24	7.80
2539	24	8.92	0	0.00	24	8.92

**Table 22.**

Warning



- Ask a qualified installer or contractor to install this product. Do not try to install the product yourself. Improper installation can result in water or refrigerant leakage, electrical shock, fire or explosion.
- Use only those parts and accessories supplied or specified by Daikin. Ask a qualified installer or contractor to install those parts and accessories. Use of unauthorised parts and accessories or improper installation of parts and accessories can result in water or refrigerant leakage, electrical shock, fire or explosion.
- Read the User's Manual carefully before using this product. The User's Manual provides important safety instructions and warnings. Be sure to follow these instructions and warnings.

If you have any enquiries, please contact your local importer, distributor and/or retailer.

Daikin Refrigeration Malaysia Sdn. Bhd. participates in the ECP Programme for Air Handling Units.  
Check ongoing validity of certificate:  
[www.eurovent-certification.com](http://www.eurovent-certification.com)

**DAIKIN REFRIGERATION MALAYSIA SDN. BHD.**  
(A member of DAIKIN group)

**(Shah Alam Factory)**

11A, Jalan Utas 15/7,  
Seksyen 15, 40200 Shah Alam,  
Selangor Darul Ehsan, Malaysia.

**(Banting Factory)**

Lot 10, Jalan Perusahaan 8,  
Kawasan Perusahaan Pekan Banting,  
42700 Banting, Selangor Darul Ehsan, Malaysia

Website: <http://drm.daikinmalaysia.com>